

Design of Decoupling Control System with High Angle of Attack Based on PV Criterion

Luo Xutao¹, Liang Xiaogeng^{1,2}, Jia Xiaohong², Jia Jie³, Zhang Xiangyang³, Zhao Ke³

¹ College of Automation Northwestern Polytechnical University, Xi'an, China

Email: Lxt0423@yahoo.com.cn

² Luoyang Photoelectric Technology Development Center, Luoyang, China

³ Nanchang Hangkong University, Nanchang, China

Email: jjjie757@sina.com

Abstract—There is a serious aerodynamic cross-coupling in the high-maneuvering missile flying at high angles of attack among each tunnel. When the effect of coupling is very weak, coupled items will generally be considered as a perturbation in the design of traditional three-tunnel, overcome the coupling factors through the design of strong robust control system. However, there is a clear theory's defects in this method: When the effect of coupling is strong, Coupling terms will change the structure of the system. Thus, decoupling need to be considered in the design of control system under high angle of attack because of the stronger aerodynamic coupling. Considering these coupling factors, this paper firstly establish small signal linear coupling model of the pitch-yaw tunnel. The decoupling controller for high angle of maneuverable missile is designed based on the multivariable control decoupling principle of P and V criterion. From the simulation, the design of decoupling control system performs well and improves the dynamic quality of the missile.

Index Terms—missile flying at high angles of attack, PV criterion, decoupling control

I. INTRODUCTION

With the reequipment of the fourth generation fighters, the new generation of short-range air-to-air missile should have a larger off-axis launching and the capacity of the over-shoulder fire as well as Omni-directional attack in order to serve the modern warfare. It is unable to complete the mission only relying on the aerodynamic surface control. Thus high-speed turning is carried out by rudder of thrust vector or other measures. However turning in the initial paragraph will lead to high angle of attack flight status. In the high angle of attack flight conditions, the greater resistance and moment of induced roll will be generated. This will result in movement of serious cross-coupling, sometimes even makes the system unstable. So it's difficult to realize design of high-quality system by the method of traditional three-channel independently. However design of decoupling control based on some advanced methods of control theory will be hard to achieve in project of flight Control System. Considering the real situation of over-shoulder fired missiles, this paper establishes mathematical model which can describe the characteristics of the missile longitudinal-lateral coupling. The control law with strong robustness is designed by decoupling principle of PV type norms. Simulation results verify the validity of the method [1.2.4.5].

II. MATHEMATICAL MODEL OF COUPLED BODY

The coupling between pitch and yaw is mainly caused by lateral induction for missile of normal-type distribution. The main reason is that airflow through missile's body isn't a symmetric. The effect is more obvious when angle of attack is more than 20°.

Small perturbation linear model:

$$\Delta \dot{\theta} = a_4 \Delta \alpha + a_4 \Delta \delta_z + d_{32} \Delta \beta \quad (1)$$

$$\Delta \dot{\psi}_c = b_4 \Delta \beta + b_4 \Delta \delta_y - h_{32} \Delta \alpha \quad (2)$$

$$\Delta \dot{\omega}_y = h_{22} \Delta \alpha - b_2 \Delta \beta - b_1 \Delta \omega_x - b_3 \Delta \delta_y \quad (3)$$

$$\Delta \dot{\omega}_z = -d_{22} \Delta \beta - a_2 \Delta \alpha - a_1 \Delta \omega_x - a_3 \Delta \delta_z \quad (4)$$

Where $\Delta \omega_x$, $\Delta \alpha$, $\Delta \omega_y$, $\Delta \psi_c$, $\Delta \theta$, $\Delta \beta$, $\Delta \delta_z$, $\Delta \delta_y$ are the increment angle separately as follows: pitch angle, attack angle, yaw angle, trajectory deflection angle, trajectory inclination angle, sideslip angle and rudder angle of pitch-yaw tunnel.

Change the small perturbations equation into the form of state equation,

The state variable is:

$$\Delta U = \begin{bmatrix} \Delta \delta_x & \Delta \delta_y \end{bmatrix}^T$$

Then get the state equations of pitch-jaw channel:

$$\begin{bmatrix} \dot{\omega}_z \\ \dot{\alpha} \\ \dot{\omega}_y \\ \dot{\beta} \end{bmatrix} = \begin{bmatrix} -a_1 & -a_2 & 0 & -d_{22} \\ 1 & -a_4 & 0 & -d_{32} \\ 0 & h_{22} & -b_1 & -b_2 \\ 0 & h_{32} & 1 & -b_4 \end{bmatrix} \begin{bmatrix} \omega_z \\ \alpha \\ \omega_y \\ \beta \end{bmatrix} + \begin{bmatrix} 0 & -a_3 \\ 0 & -a_5 \\ -b_3 & 0 \\ -b_5 & 0 \end{bmatrix} \begin{bmatrix} \delta_y \\ \delta_z \end{bmatrix} \quad (5)$$

which $X \in R^4$, $U \in R^2$

The coupling model of pitch - yaw channel which is the object of multi-input multi-output coupling control system is described in formula (5). When the attack angle (sideslip angle) becomes larger, a larger lateral (pitch) moment and side (vertical) force is induced by result of aerodynamic hinge moment. There is a

coefficient of hinge driving force (moment) h_{22} (d_{22}) and h_{32} (d_{32}). At this moment the movement of pitch perturbation to the lateral perturbation should be considered.

III. DESIGN OF DECOUPLING CONTROL LAW UNDER HIGH ANGLE OF ATTACK

A. Principle of multivariable object decoupling Units

1) Control object of P criterion and V criterion

For a coupling system with input of U_1, U_2, \dots, U_n and output of Y_1, Y_2, \dots, Y_n , there are two different kinds of coupling phenomena in essential: one is the couple between input and other tunnel and the other is between output and other tunnel. According to these characteristics, control object can be divided into two different types of form. That is P normative control object and V normative control object.

P criterion: In P criterion each input U_i will impact any output Y_i in system. Figure 1 is the schematic of this coupling. (Take dual-input dual-output system for example)

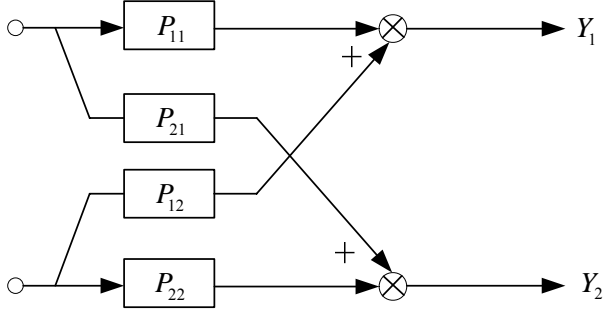

Figure 1. the Schematic of P criterion coupling

V criterion : In V criterion each output Y_i will be impacted not only U_i by input but also by the i output which goes through tunnel in the system. Figure 2 is the schematic of this coupling.

2) Best decoupling structure of bivariate P criterion control object

Study shows : V criterion is best decoupling structure of P criterion . The result of bivariate V norm specification system design is shown in Figure 3 :

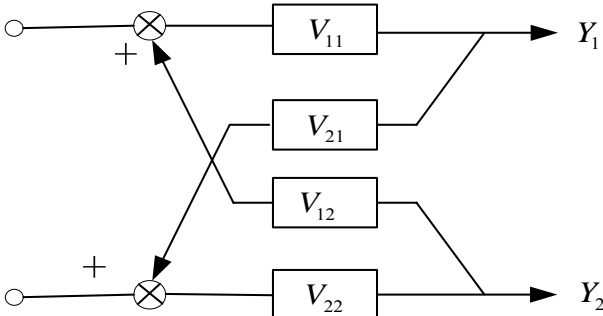

Figure 2. Schematic of V norm coupling

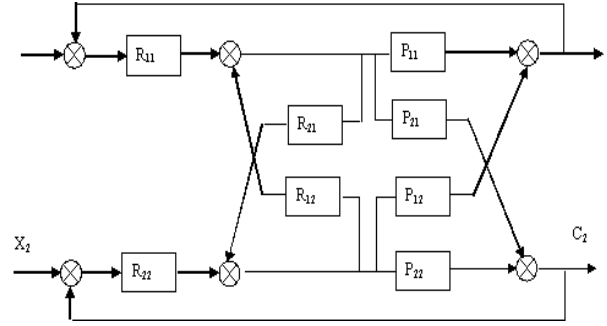

Figure 3. Best decoupling structure of bivariate P normative control object

Decoupling conditions

$$R_{12} = -\frac{P_{12}}{P_{11}}$$

$$R_{21} = -\frac{P_{21}}{P_{22}}$$

Characteristics of the system after decoupling

$$G(s) = \begin{bmatrix} \frac{R_{11}(s)P_{11}(s)}{1 + R_{11}(s)P_{11}(s)} & 0 \\ 0 & \frac{R_{22}(s)P_{22}(s)}{1 + R_{22}(s)P_{22}(s)} \end{bmatrix}$$

3) Best decoupling structure of bivariate V normative control object

For the control object of V norms, feedback decoupling method can be used to achieve the full decoupling. The result of bivariate V norm specification system design is shown in Figure 4:

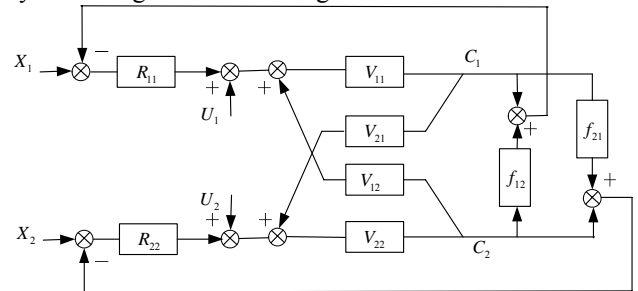

Figure 4. Full decoupling structure of bivariate V normative control object

Where

$$f_{21} = V_{21}/R_{22} = V_{21} V_{22}/W_{22}$$

$$f_{12} = V_{12}/R_{11} = V_{12} V_{11}/W_{11}$$

$$W_{11} = V_{11}R_{11}$$

$$W_{22} = V_{22}R_{22}$$

So:

$$C_1 = (V_{11}U_1 + W_{11}X_1)/(1 + W_{11})$$

$$C_2 = (V_{22}U_2 + W_{22}X_2)/(1 + W_{22})$$

B. Design of decoupling control law

The typical structure of pitch-yaw missile flight control system is showed in figure 5 ,which is not including the decoupling part.

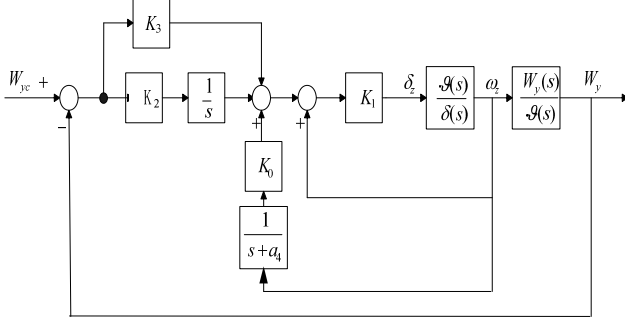

Figure 5. structure of pitch / yaw flight control system

om formula (5) it is clearly that : the effect between pitch movement and the yaw movement mainly has two aspects: power coupling and moment coupling. Because the impacts of the moment coupling are big for control system than that of power , the control system is designed by the method of decoupling to achieve decoupling. Power coupling has small impact in control system, so it is designed with the method of integral correction to achieve static decoupling;

Change moment coupling part into style of equivalent rudder angle

$$\frac{d\omega_y}{dt} = -b_2\beta - b_1\omega_y - b_3\left(\delta_y + \frac{h_{22}}{b_3}\alpha\right)$$

From above , coupling path is from the coupled angle of attack to the position of rudder . So the coupling between longitudinal and lateral channel can be described by bivariate V norms control object.

Considering object with V criterion, feedback decoupling method can be used to achieve full decoupling which is the output to the input with interference .Figure 4 shows that full decoupling structure of bivariate V norms control object. So decoupling structure of pitch - yaw coupled flight control system can be achieved which is shown in figure 6.

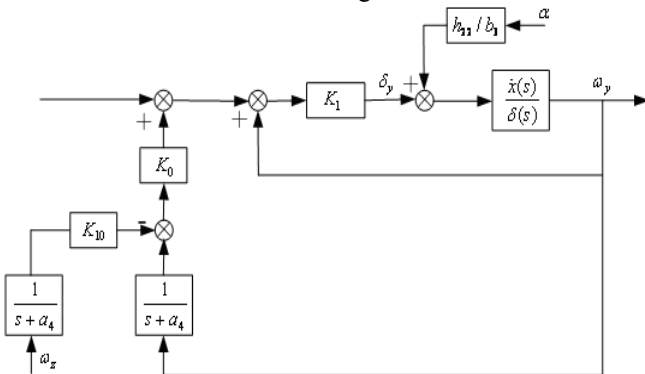

Figure 6. decoupling structure of Pitch - yaw coupled flight control system

Formula of decoupling gain:

$$f_{21} = V_{21}/R_{22}$$

Ignore the impact of damping feedback loop gain of the transmission , so decoupling gain K_{10} is:

$$K_{10} = \frac{1}{K_1 \cdot K_0} \cdot \frac{h_{22}}{b_3} \quad (6)$$

IV. NUMERICAL SIMULATION

Simulation conditions : High:2000m;Ma=1.5;Angle of attack $\alpha = 25^\circ$, Directive of pitch yaw overload 1g;Controller parameters :

$$K_2 = 0.07, K_3 = 0.000667, K_0 = 6.33, K_1 = -0.09$$

The simulation results of high angle of attack missile pitch - yaw flight control system shows in figure 7-10

Adding decoupling which express the red signal, blue indicated that they are not joined.

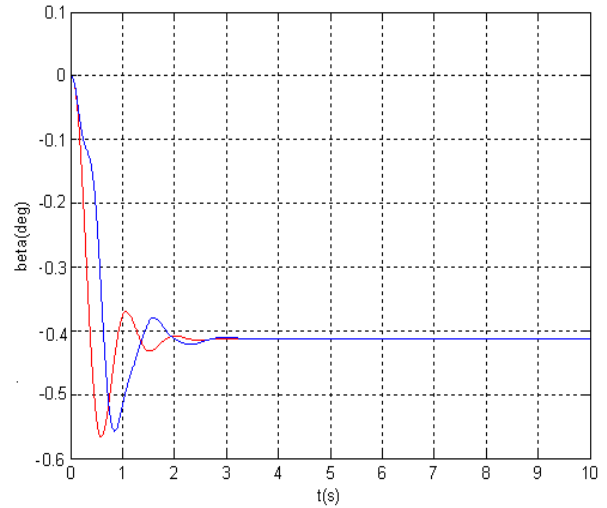

Figure 7. Response curve with Angle of attack

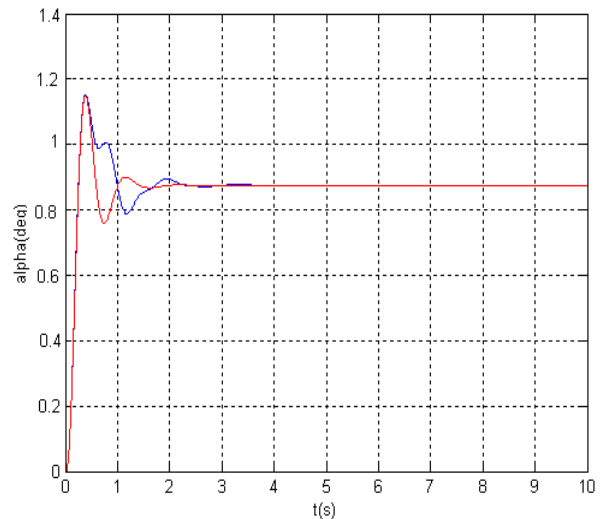

Figure 8. Response curve Sideslip angle

V. CONCLDING

Based on the aircraft pitch-yaw channel coupled mathematical model, the paper designs decoupling control system based on P-type and V-type norms multivariable decoupling control system theory, numerical simulation verifies the effectiveness of the method. The work has some reference value for engineer implement of high angle of attack missiles realize decoupling works.

REFERENCES

- [1] Lei Yanhua , Chen Shilu. The Missile Aerodynamic coupling analysis and decoupling arithmetic study [J]. Journal of Ballistics, 2003,15 (1) 14-15.
- [2] Xia Weipeng,Liu Shikao. A Missile Decoupling Control for Two Channels Cross Coupling [J]. Journal of Projectiles, Rockets,2006.26 (1) .32-34.
- [3] E. Soroka and U. Shaked A decoupling approach to the design of the two-degree-of-freedom tracking control systems[A]. Athens, Greece, IEEE, 1986.661-665.
- [4] Liu Chenghui. Multivariable process control system decoupling theory [M].Beijing , Water Conservancy and Electric Power Press,1999.13-40.
- [5] Luo Xutao,Yang Jun. Design of Lateral Flight Control System of Tiltrotor Aircraft by Using Linear Model Following Method [J]. Journal of Projectiles, Rockets,2006.26 (2).374-376.

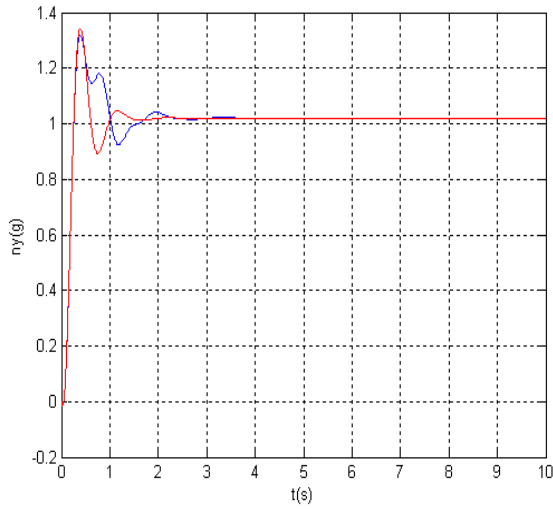

Figure 9. Response curve of Normal overload

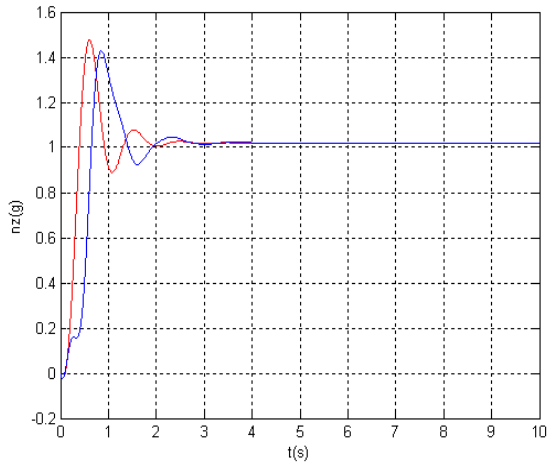

Figure 10. Response curve of Lateral load