

An IPS for Web Applications

Angelo Biscotti, Gianluca Capuzzi, Egidio Cardinale, Francesco Pagliarecci, Luca Spalazzi

Università Politecnica delle Marche — I-60131 Ancona - Italy

Email: a.biscotti@univpm.it, {capuzzi, cardinale, pagliarecci, spalazzi}@diiga.univpm.it

Abstract—This work presents an IPS for web applications that combines anomaly detection, misuse detection, and a prevention module. This approach provides us a solution that produce a number of false positives and false negatives less than traditional solutions. The proposed system is also able to update the misuse and anomaly model according to feedback received by the security manager. Finally, in our system the anomaly model has been specifically designed for web applications. We implemented and experimented our system in a real service company. From the results arises an improvement with respect to other state-of-the-art WEB-IDSs.

Index Terms—Intrusion Detection Systems, Intrusion Prevention Systems, Web Applications

I. INTRODUCTION

Web servers and web applications are often under attack by malicious software or intruders. The most part of web applications or web server-extensions are not structured with a secure criteria, so the number of attacks to them is increasing. As a consequence, well known Network and Host based Intrusion Detection Systems (N-IDS and H-IDS) (e.g., see [1], [2]) are not appropriate in this situation. We need Intrusion Detection and Prevention Systems at Application level (A-IDS and A-IPS) that are specifically designed to reveal and prevent intrusions to web applications. Concerning intrusion detection, in literature there are three possible approaches:

- *Misuse Detection* - current requests are compared with malicious requests stored (as signatures) into a knowledge base. Unfortunately, it is really difficult to maintain updated the signatures because of the high number of new vulnerabilities daily discovered. This produces a lot of *false negatives (FN)*.

- *Anomaly Detection* - current requests are compared with the (previously stored) normal behavior in order to reveal anomalies. This approach has the disadvantage that it is difficult to establish what is the normal behavior and, thus, it produces a lot of *false positives (FP)*.

- *Misuse+Anomaly Detection* - in order to avoid the above problems, misuse detection may be complemented with anomaly detection. This should reduce both FP and FN. In literature, such possibility has been analyzed by E. Tombini *et al.* [3]. This work points out as for web application it is better to have the misuse-based module at the first stage and the anomaly-based component at the second stage. Indeed, the solution with the anomaly-based element at the first block has three advantages: it filters a high percentage of true negative, it has a low computational cost (the misuse component is used

only for a restricted number of cases), it has few false positives thanks to the misuse component. Nevertheless, this solution has an high number of disadvantages for a web-application, that is our target: we have a relative high number of false negatives because of attacks not revealed by the anomaly component are not processed by the second module; an event detected as dangerous by the misuse component is processed again by the anomaly module; events that are not correctly recognized are classified at the highest level of danger. On the other hand, the second solution that uses the misuse-based component at the first block presents the following advantages: great reactivity, since the misuse based component filters the attacks in an efficient way; a good solution for conflicts about events not well recognized by the anomaly and misuse modules: in the first case they are classified like true positive and in the second case like false positive; a low number of false negatives; and the anomaly based component doesn't need to process again an event classified dangerous by the first module. This solution has only two disadvantages: the relative high number of false positives and a high computational cost. Nevertheless, these problems can be easily minimized. The number of false positive may be reduced by means of an appropriate configuration of the anomaly based component. Moreover, the computational cost is critical only for in-line systems, while for on-line systems may be acceptable a little delay.

Concerning misuse detection systems, their study began with J. Anderson's work in 1980s on categorizing threats [4]. He proceeded to suggest ways to detect these threats by associating the threats with abnormal and known suspicious patterns in the audit trail. This is based on the assumptions that misuse behavior exhibits distinguishable patterns from normal usage behavior and that these patterns are reflected in the audit trail. Since then, several misuse detection systems have been proposed (e.g., see [1], [2]).

Concerning anomaly detection systems, they have been proposed for the first time by D.E. Denning [5], that presented an abstract model of a real-time intrusion detection system (IDES), based on the idea that an use of the system different from previous uses may be a signal of an improper use. A lot of other techniques have been proposed by several authors. A.K. Ghosh, *et al.* [6] used a neural network model to identify anomalous behaviors. L. Portnoy, *et al.* [7] proposed an unsupervised clustering algorithm to classify normal and abnormal activity. T. Lane and C.E. Brodley [8] presented a machine learning model based on IBL (instance-based learning) applied

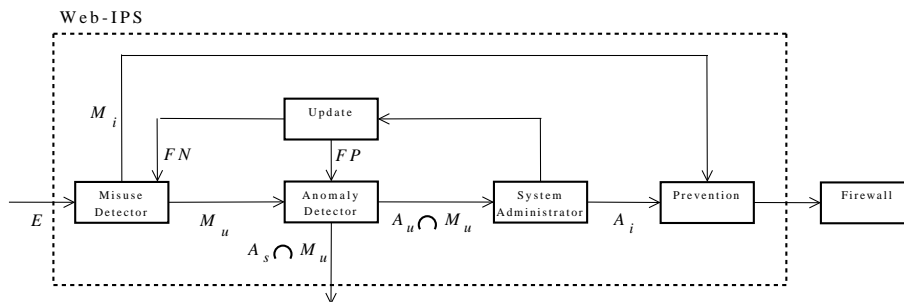

Fig. 1. System architecture.

to system applications. H. Feng, *et al.* [9] improved the static analysis for intrusion detection using PDA (push-down automaton). A limitation of all the above works consists of the fact that they deal with static applications: applications that do not change their behavior. This makes relatively easy identifying anomalies. In the case of web applications, we have dynamic entities and their behavior is strictly depending on the interaction with the users. In this respect, it is noteworthy the work by C. Kruegel, *et al.* [10] where the authors proposed statistical and probabilistic techniques.

Concerning the integration of anomaly based and misuse based techniques, Cisco Systems [11] and Real Secure [12] adopted this approach in their commercial systems, but the anomaly component plays a marginal role in such systems that still are basically misuse detection applications.

Finally, intrusion prevention systems integrate an intrusion detection component with a module that can react, in real-time, to block or prevent intrusions [13]. Intrusion prevention systems (IPS) evolved in the late 1990s to resolve ambiguities in passive network monitoring by placing detection systems in-line. Early IPS were IDS that were able to implement prevention commands to firewalls and access control changes to routers (e.g., see [2]).

The brief analysis reported above has had two consequences to this work: First, we have adopted an architecture in three stages: Stage 1 consists of a misuse detection module; Stage 2 consists of an anomaly detection module; Stage 3 consists of a prevention module. Second, we have mainly focused on anomaly detection algorithms and carefully designed the corresponding module since it is the most critical part of the system. Third, we have a specific module for updating both the anomaly model and the misuse model (i.e., updating the signature base) according to the feedback received by the security manager. This allows us to improve the sensitivity of the system and to reduce the number of false alarms.

The paper is structured as follows: Section II provides an overview to system architecture. Sections III and IV describe the misuse and anomaly detection model, respectively. The prevention model is presented in Section V. Section VI reports some experimental results. Finally, some conclusions are discussed in Section VII.

II. OVERALL DETECTION MODEL

Our system analyzes on-line a temporal series of HTTP requests as logged by most common web server (for example, Apache [14]). The analysis deals with both GET and POST requests to HTML pages, server-side programs, or active documents. The system architecture is depicted in Figure 1. The system input is a request R , extracted from web server access log file. A request R can be expressed in several ways depending on custom web server logging directives. In our work, we assumed that requests were logged in the Common Log Format (CLF) or Extended Common Log Format (ECLF). In these formats the most important features logged by web server are the IP source address, the date and the time of the request, the path to the desired web page (*path*), and sometimes the optional query string (*q*). The query string is used to eventually pass parameters to the referenced script and it is identified by the character "?". A generic query string normally consists of an ordered list of n pairs of parameters with their corresponding values, so q can be expressed as $q = (p_1, v_1), (p_2, v_2), \dots, (p_n, v_n)$ where $p_i \in P$ (P is the set of all parameters) and v_i is a string. Another important feature is the status code of the request. Figure 2 shows an example of a request logged by a web server in ECLF format, where elements used in the analysis are underlined.

Let E be the set of events, i.e. the set of requests R processed by the system. Let M_i and M_u be the subsets of E that represent the sets of events declared *intrusive* or *unknown*, respectively, by the misuse detection component and let A_s and A_u be the subsets of E that represent the sets of events declared *safe* or *unsafe*, respectively, by the anomaly detection component. The misuse component tries to match $R \in E$ with a set of signatures and returns an alarm if the pattern matching succeeds ($R \in M_i$). On the contrary, events declared unknown in the first step ($R \in M_u$) are then analyzed by the anomaly detection component. When the anomaly detector declares R safe ($R \in A_s$), the event is assumed completely irrelevant ($R \in M_u \cap A_s$) and is filtered out. On the contrary, an alarm is returned when R is declared intrusive ($R \in A_u$). Notice that subset $M_u \cap A_u$ represents the set of events declared unsafe (potentially intrusive) by the anomaly detector even if declared unknown (potentially safe) by the misuse detector. Therefore, these events can be either false positives issued by the anomaly detector or false negatives issued by the misuse detector. As a conse-

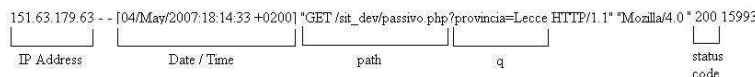

Fig. 2. A web server access log entry.

quence, our system can be configured in such a way to let system administrator manually interpret these events. When she/he considers the request a false positive, the anomaly model is updated, the misuse model is updated (by adding a new signature), otherwise. When an alarm is returned, either by the misuse component or by the anomaly component, the prevention component tries to automatically apply some prevention rules in order to block the communication with client that generated the intrusive event. This means changing rules of a firewall.

III. MISUSE DETECTION MODEL

The misuse detection component is used to detect known malicious HTTP requests and report them as attacks. For example, the presence in the request of the word "SELECT" or "WHERE" could be used to detect an attempted incorrect use of SQL commands to retrieve sensible data. The misuse detection process uses a list of regular expressions, which items represent manifestations of the most common attacks. These regular expression are used to match against the analyzed request and an alarm is returned when a match occurs. We used the Java regex package to implement the mechanism of pattern matching, which is conformant with Level 1 of Unicode Technical Standard #18: Unicode Regular Expression Guidelines [15], plus RL2.1 Canonical Equivalents. Currently, the basic list contains about 70 regular expressions, but consider that the system administrator can add new signatures (new regular expressions) as explained in Section II. The new regular expression is automatically generated from the request without stopping system execution. Regular expressions are compiled at run-time, before the matching process starts. The list of regular expressions is specified into a text file, in an XML-based format. For example, see the following expression:

```
<signatures>
  <expression name="Cross-site Scripting">.*(script)+.*
  </expression>
  <expression name="Directory Trasversal">*(\.\./)+.*
  </expression>
  <expression name "SQL Injection">.*
    (select|insert|update|delete|union|--)+.*
  </expression>
  [...]
</signatures>
```

At this time, the automatic generation of a signature is made simply adding the tagged request at the end of the list of regular expressions.

IV. ANOMALY DETECTION MODEL

The anomaly detection component provides a model of the "normal behavior" of users and applications. The basic assumption is that, in case of intrusive actions, the behavior of users or applications differs substantially

from normal behavior and this difference can be expressed quantitatively. The behavior of software entities in web applications is very dynamic and it is strictly connected with user interaction, which often governs the visualization process of data and informations through the choice of a set of values associated to some parameters. Additionally, each web application is different from others in terms of number and type of parameters to elaborate. Our approach was initially based on the model proposed by C.Kruegel, *et al.* [10], which uses several different *evaluations* about requests, parameters and their relationship to detect anomalous entries. An evaluation is a set of statistical procedures used to evaluate a certain *feature* of a request. A feature can be related to a single parameter of a query string (e.g. the string length of a particular parameter value), to all the parameters (e.g. the order of parameters in a query string), or to some relationships between a request and others related to a specific web page or script *r* (e.g. number of requests in a time slot). Our model differs from Krueger *et al.* model since we used only six feature evaluations and different statistical tools.

- Length of parameter values
- Distribution of characters in parameter values
- Presence of enumeration-type parameters
- Presence/absence of a given parameter in a request
- Parameter order in a request
- Access frequency to a web resource

The model operates in three distinct steps: *learning*, *tuning*, and *detection*.

Learning. The learning phase works for establishing the normal behavior on the base of a training set. In other words, the goal is the definition of a *profile* (*P*) for each web page/script. The six features are evaluated on a "sufficiently" large set of normal access requests to a web page/script (first 1000 in our implementation) in order to build the related profile. For this purpose we used historical access log data files, gathered from the system administrator of a small Italian company. For each feature, we estimate the corresponding probability distribution; i.e., what is the probability of observing a certain value for a given feature in a request. The feature evaluations and the corresponding probability distributions contained in a *profile* are reported in Table I. Notice that the evaluation of feature # 6 is computed considering the requests altogether.

Tuning. The tuning phase has the goal of setting a detection threshold. This task is performed in three steps: First, we set a weight (w_e) for each feature. The w_e values are established a priori and, if needed, they can be manually adjusted by the security manager after a brief analysis process on historical data of web server. Afterward, for each web page/script (profile *P*), we compute the *normal*

TABLE I
WEB PAGE/SCRIPT PROFILE.

e	Request Features	Measures	Probability Distribution	# of Requests
1	Length of parameter values	Mean (μ), Variance (σ^2)	Cantelli Inequality	1
2	Distribution of characters in parameter values	Mean (E_i)	χ^2 Distribution	1
3	Parameters of type Enumeration	Correlation (ρ, g, f)	Degenerate Distribution	1
4	Presence/absence of a parameter	Parameter Sets (S_q)	Degenerate Distribution	1
5	Parameter order in a request	Adjacency Matrix (M)	Degenerate Distribution	1
6	Access frequency	Mean (μ), Variance (σ^2)	Cantelli Inequality	all

score ($NS(r_P)$) of each request r_P in the training set, as follows:

$$NS(r_P) = \sum_{e=1}^6 w_e \cdot (1 - p_e(r_P)) \quad (1)$$

Concerning the above formula, we have to take into account the following remarks. First, when r_P contains several parameters pr_1, \dots, pr_n , for $e = 1, \dots, 4$, we have $p_e(r_P) = \min_{i=1}^n p_e(r_P, pr_i)$, where $p_e(r_P, pr_i)$ is the probability for the single parameter pr_i . This allows us to avoid that a malicious user hides a single invalid input into a series of valid inputs. Second, $p_6(r_P)$ is computed taking into account all the requests received in the last 24 hours before request r_P . Third, when we have a script without parameters, the profile P contains only two evaluations: $e = 4$ and $e = 6$.

Finally, for each web page/script (profile P), we set the initial *anomaly score threshold*, as follows:

$$T_0(P) = \max_{r_P} NS(r_P) \quad (2)$$

Detection. Intuitively, in the detection phase we compute the anomaly score of a given request and compare it with the score obtained in the tuning phase: the higher is the anomaly score, the farer away is the behavior from the normal behavior. The *anomaly score* ($AS(q_P)$) for the current request q_P to the web page/script with profile P is computed as follows:

$$AS(q_P) = \sum_{e=1}^6 w_e \cdot (1 - p_e(q_P)) \quad (3)$$

The anomaly score is computed taking into account the same remarks reported above for the normal score. After that, the anomaly detection module takes a decision according to the following rule:

- When $AS(q_P) < T_0(P)$, q_P is a normal request.
- When $AS(q_P) \geq T_0(P)$, an alert is sent to the security manager.
 - If the security manager does NOT validate the request, q_P is an anomaly request ($q_P \in A_i$).
 - If the security manager validates the request, then q_P is a normal request and the anomaly model must be modified. This means that a new threshold must be set. The *update* module sets $T_1(P) = AS(q_P)$.

LENGTH OF PARAMETER VALUES. The intuitive idea is: “when a parameter value is too long, it is an anomaly”. Indeed, for example, to overflow a buffer in a target application, an intruder needs to send a large amount of data, depending on the length of the buffer. In the training phase the goal of this evaluation is to approximate the actual but unknown distribution of parameter

lengths, so in the detection phase, the system can detect instances that significantly deviate from the observed normal behavior.

Learning: The length of values associated with a certain parameter in a request can be expressed as a random variable. Therefore, it is possible to estimate the corresponding mean value μ and variance σ^2 associated with it, by calculating the sample mean and the sample variance for the lengths l_1, l_2, \dots, l_h of the values in the training set associated with the given parameter (assuming that in the training set we have h requests with that parameter). The cost of this evaluation is proportional to the number of requests analyzed during the learning phase plus a constant term to compute the mean and the variance.

Tuning & Detection: In tuning and detection phases, we need to compute the probability of having a certain length l . This process must take into account that, in several cases, the length of a parameter value may have a large variance. Furthermore, a parameter value whose length is less than the mean value μ , can be considered normal ($p(l) = 1$). Indeed, we are looking for anomalous requests in which a large amount of data is injected in one or some values. An estimation method that satisfies the above requirements is provided by the *Cantelli Inequality* [16].

$$p(l) = \begin{cases} 1 & l \leq \mu \\ \frac{\sigma^2}{\sigma^2 + (l - \mu)^2} & l > \mu \end{cases} \quad (4)$$

Equation (4) is an efficient metric to model decreasing probabilities for lengths greater than a given mean value. It establishes an upper bound for such a probability.

DISTRIBUTION OF CHARACTERS IN PARAMETER VALUES. The intuitive idea is: “when a character appears too much/too less in the parameter value of a given request, it is an anomaly”. Often user input has a regular structure, is mostly human-readable, and often contain printable characters only. Most of characters in regular values are letters, numbers, or few special characters. On the other hand, sometimes a malicious user sends binary data (e.g., buffer overflow attacks), or inject a string with a noticeable strange character sequence (e.g., with many repetition of the dot character in directory traversal exploits). When we analyze a lot of requests containing the same parameter, we can observe that characters appear with similar frequencies. For example, character frequencies in English words are different from character frequencies in Italian words. Therefore, when we sort in frequency descending order all the possible characters in a legitimate string, frequencies slowly decrease in value. In case of malicious input, instead, these frequencies

often decrease extremely fast. This can be the result of a certain padding character that is repeated many times in a buffer overflow attack or of many occurrences of the dot character in a directory traversal attempt. Therefore we assume that the character distribution of a value is represented by the array of its relative frequencies sorted in descending order.

Learning: For a given parameter, for each value contained in the training set, we count the number of occurrences of each character. Afterward, we compute the mean frequency of each character for all the values in the training set and sort the characters in descending order. We group the characters in six intervals defined as follows: [0], [1, 3], [4, 6], [7, 11], [12, 15], [16, 255]¹. The k -th character in the descending order belongs to interval $i = [a, b]$ if and only if $a \leq k < b$. For each interval i , we compute the mean frequency F_i of characters in the interval. The cost of building this model is linear in the number of parameters that are analyzed during this phase. For each parameter, establishing the character distribution has a cost that is proportional to the length of its value string.

Tuning & Detection: In tuning and detection phases, we need to compute the probability of having a certain character distribution. First of all, for each value, we count how many characters of a given interval i we have, we denote this number with O_i . We then compute χ^2 as reported in Equation (5).

$$\chi^2 = \sum_{i=0}^5 \frac{(O_i - E_i)^2}{E_i} \tag{5}$$

where $E_i = F_i \cdot l$ and l is the length of the analyzed value. Afterward, we apply the Pearson χ^2 statistical test [16] to estimate the probability. The probability is read from a predefined table (Table II) using χ^2 and the *degrees of freedom*. The degrees of freedom are calculated as $(\text{number of intervals} - 1) = 5$.

TABLE II
PROBABILITY VALUES FOR 5 DEGREES OF FREEDOM

χ^2	p	χ^2	p
0.41	0.995	9.24	0.1
0.55	0.99	11.07	0.05
0.83	0.975	12.83	0.025
1.15	0.95	15.09	0.01
1.61	0.9	16.75	0.005

PRESENCE OF ENUMERATION-TYPE PARAMETERS. The intuitive idea is: “when we have a parameter of type enumeration, we can admit only values in the enumeration, we have an anomaly, otherwise; when the parameter is not of type enumeration, we can admit all the values”. As a consequence, first of all we have to establish whether the parameter is of type enumeration; in other words, whether the values of such a parameter are drawn from a limited set of possible alternatives (i.e., “checkbox”, “radio”, or “select” HTML input types). When a malicious user attempts to use these parameters to pass to the analyzed

script values that are not in the trusted set, the intrusion attempt can be detected. When an enumeration type can not be identified for a certain parameter, it is assumed that the parameter values are random and no attacks can be detected by this evaluation.

Learning: The goal of this phase is to establish whether the parameter is of type enumeration; if so, we have to build the set V of legal values for that parameter. Intuitively, when the set of values observed for that parameter in the training set is (almost) time-invariant (after a short transitory phase), this is a clue that the parameter is of type enumeration. When the set of values is growing proportionally to the number of analyzed requests in the training set, this suggests that the parameter is not of type enumeration. Formally, we proceed as follows: 1) We associate a progressive number $x(v_i)$ to each value v_i encountered during this phase. 2) We build the set $V_h = \{v_1, v_2, \dots, v_n\}$ of values encountered till the h^{th} request in the training set. 3) Let v the value contained in the h^{th} request, we build two auxiliary sequences f and g as follows:

$$f_h(x(v)) = x(v) \tag{6}$$

$$g_h(x(v)) = \begin{cases} g_h(x(v) - 1) + 1 & v \in V_h \\ g_h(x(v) - 1) - 1 & v \notin V_h \\ 0 & x(v) = 0 \end{cases} \tag{7}$$

Afterward, for each parameter we compute the correlation parameter ρ :

$$\rho = \frac{\text{Covar}(f, g)}{\sqrt{\text{Var}(f) \cdot \text{Var}(g)}} \tag{8}$$

If $\rho < 0$, then we have an enumeration type parameter and $V = V_{last}$ (i.e., V_h when h is the last request in the training set) is the set of legal values. If $\rho \geq 0$, it is not an Enumeration Type Parameter. The cost of building this model is strictly connected to the calculation of the covariance between these two simple functions. This cost depends on the number of analyzed requests.

Tuning & Detection: In tuning and detection, we need to estimate the probability that a given parameter has the current value. For enumeration-type parameters, we use a degenerative distribution, let v the current value, $v \in V$ is considered a normal behavior ($p(v) = 1$), it is an anomaly otherwise ($p(v) = 0$), formally:

$$p(v) = \begin{cases} 1 & v \in V \\ 0 & v \notin V \end{cases} \tag{9}$$

For non enumeration-type parameters, the system must accept any value, namely:

$$p(v) = 1 \tag{10}$$

PRESENCE/ABSENCE OF A GIVEN PARAMETER IN A REQUEST. The intuitive idea is: “when a mandatory parameter is missing or the request has a wrong parameter, we have an anomaly”. In other words, in learning phase, we have to establish whether and which parameters must be present. Afterward, in tuning and detection, we have three possible situations: 1) when

¹We assume to use the ASCII code, i.e. a 8 bits code.

a *parameter must be present*, its absence in a request is an anomaly; 2) when a *parameter must be absent*, its presence in a request is an anomaly; 3) any other situation can be considered a *normal behavior*.

Learning: the goal of this phase is to establish whether a script has mandatory parameters and, if so, to create a model of acceptable subsets of parameters that appear simultaneously in a query string. This is done simply by storing each distinct subset $S_{r_P} = \{p_i, \dots, p_k\}$ of parameters for each request r_P in the training set. As a consequence, each subset S_{r_P} contains the parameters that appear simultaneously in request r_P . Afterward, the system adopts the following decision rules:

- 1) When all the requests r_P contain parameters ($S_{r_P} \neq \emptyset$, for each r_P), the web page/script P "MUST" contain parameters.
- 2) When only some requests r_P contain parameters, P "MAY" contain parameters.
- 3) When no request contains parameters ($S_{r_P} = \emptyset$, for each r_P), P "MUST" contain "NO" parameters.

Tuning & Detection: In tuning and detection phase, we proceed as follows: Let $S(q_P)$ the set of parameters in the current request q_P .

- The request MUST contain parameters: if there exists r_P s.t. $S(q_P) = S_{r_P}$, then q_P is a normal request, otherwise, it is an anomaly.
- The request MAY contain parameters: each request is a normal request.
- The request MUST contain NO parameters: if $S(q_P) = \emptyset$, then q_P is a normal request, otherwise, it is an anomaly.

PARAMETER ORDER IN A REQUEST. The intuitive idea is: "legal requests often contain the same parameters in the same order, we have an anomaly otherwise.". Indeed, hand-crafted requests, as the requests by a malicious user, may have parameters in an arbitrary order.

Learning: The order relationship among all the k parameters of a legitimate query string are determined during this phase. We assume that a parameter p_t of a script precedes another parameter p_s if and only if there exists S_{r_P} such that $p_t, p_s \in S_{r_P}$ and p_t comes before p_s in the parameter list of queries where they appear together. In order to store this relationship, we use a matrix M of ($s \times s$) elements, where s is the total number of parameters associated with the analyzed script and $M_{ij} = 1$ if p_i precedes p_j , 0 otherwise. Matrix M is built as follows:

- 1) The initial value is set to 0, i.e., $M_{ij} = 0$ for each i, j .
- 2) For each request r_P in the training set, let p_1, p_2, \dots, p_n be the sequence of parameters in r_P , for each i, j such that $0 < i \leq j \leq n$, we set $M_{ij} = 1$. Notice that, often we have $M_{ts} \neq M_{st}$, but sometimes, when p_t and p_s appears in both the orders in different requests, we have $M_{ts} = M_{st}$. The cost of building this profile is not high, because the total number of parameters processed by a generic script is usually relatively small.

Tuning & Detection: In tuning and detection phases, the system checks whether the parameters of a request sat-

isfy the order constraints determined during the learning phase.

Let q_P be the current request, let p_1, p_2, \dots, p_n be the sequence of parameters in q_P .

- If for each i, j such that $0 < i \leq j \leq n$, $M_{ij} = 1$, then it is a normal request ($p(q_P) = 1$).
- If there exists i, j such that $0 < i \leq j \leq n$ and $M_{ij} = 0$, then it is an anomaly ($p(q_P) = 0$).

ACCESS FREQUENCY TO A WEB PAGE OR SCRIPT. The intuitive idea is: "when a web page/script receives too much/too less requests, it is an anomaly.". Indeed, different web pages/scripts normally are invoked with different frequencies. Monitoring a specific web page or script in a sufficiently long time interval, one can observe that the access frequency remains relatively constant. It is possible to distinguish between two types of access frequencies for each web page or script. The first one is the frequency based on accesses from the same client (we used the IP address). The second one is the frequency based on accesses from all the clients. When a malicious user attempts a DoS (Denial of Service) exploit for a certain script, the number of accesses observed in a short time interval from that client can increase drastically. Similarly, the frequency of all accesses can grow fast in case of DDos (Distributed DoS). Furthermore, when an attacker probes the system looking for vulnerabilities or tries to guess parameter values, it sends several requests in a short time interval. Therefore, any change in access frequencies with respect to frequencies observed in the learning phase can indicate an intrusion. **Learning:** The objective of this phase is to build a model of normal access frequencies for each web page or script. To determine the expected normal access frequencies, the time period between the first and the last request in the training data set is divided into consecutive time intervals of a fixed size (60 seconds in our implementation). Afterward, for each interval, we count how many accesses there are for each client (sender IP address) and how many accesses there are globally (from all the clients). The access frequency for each IP and the overall access frequency can be considered as random variables, with their own means and variances (μ_{IP}, σ_{IP}^2 and μ, σ^2 respectively). These values represent the normal requests to the web page or script. The cost of building this profile is proportional to the number of requests that are analyzed during the training period.

Tuning & Detection: In tuning and detection we have to estimate the probability that the access frequency in the current time interval. Therefore, time is divided into intervals of the same length used in the learning phase (i.e., 60 sec.). Let q_P be the current request.

We compute:

- f_1 (the frequency in the current time interval of accesses to P from the same sender of the current request) and
- f_2 (the frequency in the current time interval of accesses to P from any sender).

We estimate:

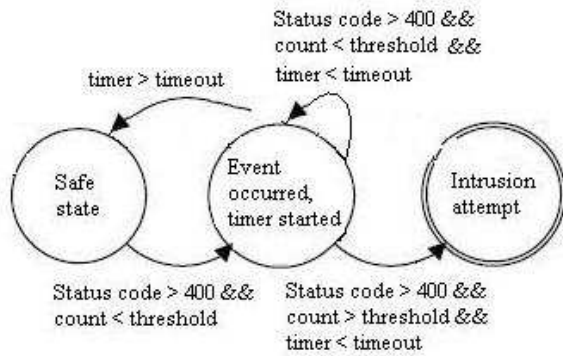

Fig. 3. Repeated failed access prevention process.

- $Pr(f_1)$ (the probability of having a frequency f_1 estimated by means of the Cantelly Inequality applied to μ_{IP} and σ_{IP}^2) and
- $Pr(f_2)$ (the probability of having a frequency f_2 estimated by means of the Cantelly Inequality applied to μ and σ^2)

Afterward, we can compute the overall probability as follows:

$$p_6(q_p) = \sum_{i=1}^2 u_i \cdot Pr(f_i) \quad (11)$$

where u_i are weights initially set to 1/2 that can be adjusted by the security manager.

V. PREVENTION MODEL

The intrusion detection system described above is equipped with a rule generation engine, in order to automatically stop the communication between the intruder and the analyzed web server in cooperation with a firewall. This software module starts its execution after the occurrence of certain events and if this process completes successfully, an access deny rule for this client will be added to firewall access rules. We used two event generator models to drive the rule generation process, the evaluation of repeated failed accesses to the server (HTTP response status code ≥ 400) and the evaluation of a parameter value type and length (e.g., buffer overflow attempts).

REPEATED FAILED ACCESS. The repeated failed access scenario checks if there are multiple client errors, including failed authentication attempts, from a particular client or subnet. This type of activity is a strong indication that a malicious user is attempting to probe the web server to gain information for future attacks. In order to perform this type of evaluation, we need to count the number of subsequent wrong requests and define two other evaluation parameters: the maximum number of repeated failed accesses (*threshold*) that are allowed and the time interval (*timeout*) above which the intrusion attempt can be considered terminated. This process can be represented as a statechart, as depicted in Figure 3. When a wrong request is performed by a certain client, a new instance identified by the IP address of this client is created. If a *timeout* occurs the instance is removed,

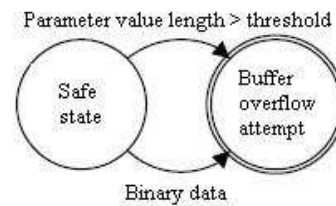

Fig. 4. Buffer overflow prevention process.

otherwise any subsequent wrong request increments the count of failed accesses and resets the time counter. If the *threshold* is overreached, a deny rule is generated and added to the firewall. *IP spoofing* cannot be handled with this process.

BUFFER OVERFLOW ATTEMPT. The presence of binary data in a request or an extremely long request are strong indications of an attempt to exploit a buffer overflow. When one of these two situations have been detected, a deny rule is generated and added to the firewall. This process can be represented as a statechart, as well, see Figure 4. Notice that when a buffer overflow exploits a vulnerability in the web server code, it may be possible that a log entry would never be created and the attack would go undetected.

VI. EXPERIMENTAL RESULTS

System evaluation has been performed by gathering on-line (in two different experiments) real data from the main web server of an Italian company, SIMobile s.r.l. (www.simobile.it). The IPS has been configured and integrated with the web architecture (e.g., operating system, web server, DBMS), by installing it as a service. LEARNING & TUNING. The learning and tuning phases have been performed off-line, by means of analyzing a database of historical legitimate HTTP/HTTPS requests. We used them to model the normal system behavior. In our experiments, the weight w_e of Equation (1) has been set to $1/6 = 0,167$. Table III shows relevant data about the learning set.

TABLE III
LEARNING SET DATA

Time interval	Log size	# of requests	# of profiles
165 days	16 MByte	87284	260

DETECTION. We experimented the detection phase for 55 days and evaluated systems by means of appropriate metrics. The system has been evaluated by analyzing on-line the HTTP/HTTPS traffic towards the monitored web server. The weight w_e of Equation (3) has been set to $1/6 = 0,167$. There are several metrics to evaluate the effectiveness of an intrusion prevention system. In our work, we used the most common ones [17], [18], as reported in Table IV Where TP, FN, FP, FN are true positives, false negatives, false positives, and false negatives, respectively. The test has a high degree of effectiveness when sensitivity and specificity values are close to 1.

TABLE IV
LEARNING SET DATA

Sensitivity (Sen)	$\frac{TP}{TP+FN}$
Specificity (Spe)	$\frac{TN}{TN+FP}$
Positive predictive value (PPV)	$\frac{TP}{TP+FP}$
Negative predictive value (NPV)	$\frac{TN}{TN+FN}$
Prevalence (Prev)	$\frac{TP+FN}{TP+FN+FP+TN}$
False Positive Rate (FPR)	$\frac{FP}{TN+FP} = 1 - \text{specificity}$
False Negative Rate (FNR)	$\frac{FN}{FN+TP} = 1 - \text{sensitivity}$

Obviously, the test has a high degree of effectiveness when the false positive/negative rate is close to 0. Table V reports the results of one of the two experiments. The

TABLE V
EVALUATIONS RESULTS

Monitoring days	55	alerts	28	Sen	1
Request logged	18894	TP	17	Spe	0,997
Suspicious events	28	TN	3655	FPR	0,003
Intrusive events	17	FP	11	FNR	0
		FN	0	PPV	0,607
		Prev	0,0046	NPV	1

number of false negatives can not be calculated automatically since it represents the cases when the system fails to identify a potential intrusive behavior. Therefore, the number reported in Table V has been computed day by day, with the help of the system administrator, whose task was to identify potentially strange requests not signaled by the system (about $18894 / 55 = 343$ requests per day).

VII. CONCLUSIONS

In this work, we considered the security problem of web-applications and the application of Intrusion Prevention Systems to this kind of systems. We proposed a model that improves the previous model proposed by [10]. In this model, we combined an anomaly detection approach with a misuse detection approach and a prevention model. Indeed, the best way to reveal web application attacks is to use the precision of signature based systems with the flexibility of anomaly detection systems and to solve problems coming from the combination of two approaches. Concerning anomaly detection, we obtained a great advantage combining different evaluation systems to cover the great number of attack typologies. The model proposed does not need any specific configuration, but only a training period. We implemented this model in a IPS that we experimented in a real context. Table

TABLE VI
IPS COMPARISON

Sistem	Sensitivity	FP/ # logs	DATA
Our IPS	100%	0,02% - 0,06 %	Real Data
[10]	100%	0,002% - 1,45%	Simulated
[19]	n.a.	0,069%	Real Data

VI shows that our results are comparable with the main reference work [10] in terms of false positives, even if in the worst cases, the system proposed in [10] has the ratio FP/ # logs worse than our system. Nevertheless, notice that their results came from a simulation, whereas we

applied our IPS to a real company network. Furthermore, the Positive Predictive Value is about 60 %, that is a typical value of PPV for IDS/IPS, as described in [18] and [17]. False positives in particular, occurred in the first days of monitoring and then decreased, as consequence of adjusting detection thresholds.

REFERENCES

- [1] P. A. Porras and P. G. Neumann, "EMERALD: Event monitoring enabling responses to anomalous live disturbances," in *Proc. 20th NIST-NCSC National Information Systems Security Conference*, 1997, pp. 353-365.
- [2] M. Roesch, "Snort: Lightweight intrusion detection for networks," in *Proceedings of the 13th Conference on Systems Administration (LISA-99)*. Berkeley, CA: USENIX Association, Nov. 7-12 1999, pp. 229-238.
- [3] E. Tombini, H. Debar, L. Me, and M. Ducasse, "A Serial Combination of Anomaly and Misuse IDSes Applied to HTTP Traffic," in *Proceedings of the Twentieth Annual Computer Security Applications Conference*, December 2004.
- [4] J. Anderson, "Computer Security Threat Monitoring and Surveillance," James P. Anderson Co., Fort Washington, Pennsylvania, Tech. Rep., April 1980.
- [5] D. Denning, "An intrusion detection model," *IEEE Transactions on Software Engineering*, vol. 2, no. 13, pp. 222-232, 1987.
- [6] A. Ghosh, J. Wanken, and F. Charron, "Detecting anomalous and unknown intrusions against programs," in *Proceedings of the Annual Computer Security Application Conference (ACSAC)*, vol. AZ, December 1998, pp. 259-267.
- [7] L. Portnoy, E. Eskin, and S. Stolfo, "Intrusion detection with unlabeled data using clustering," in *Proceedings of ACM CSS Workshop on Data Mining Applied to Security, Philadelphia, PA*, November 2001.
- [8] T. Lane and C. Brodley, "Temporal sequence learning and data reduction for anomaly detection," in *Proceedings of the ACM Conference on Computer and Communications Security, San Francisco*, ACM Press, 1998, pp. 150-158.
- [9] H. Feng, J. Giffin, Y. Huang, S. Jha, W. Lee, and B. Miller, "Formalizing sensitivity in static analysis for intrusion detection," in *Proceedings of the IEEE Symposium on Security and Privacy, Oakland, CA*, 2004.
- [10] W. Robertson, G. Vigna, C. Kruegel, and R. Kemmerer, "Using Generalization and Characterization Techniques in the Anomaly-based Detection of Web Attacks," in *Proceeding of the Network and Distributed System Security Symposium (NDSS)*, San Diego, CA, 2006.
- [11] Cisco, "Cisco intrusion prevention system," <http://www.cisco.com/en/US/products/sw/secursw/ps2113/index.html>, Tech. Rep.
- [12] IBM, "Ibm internet security systems prevention network intrusion preventionsystem," http://www.iss.net/products/product_sections/Intrusion_Prevention.html, Tech. Rep.
- [13] B. Foo, M. Glause, G. Modelo-Howard, Y.-S. Wu, S. Bagchi, and E. Spafford, *Information Assurance: Dependability and Security in Networked Systems*. Morgan Kaufmann Publishers, 2007, ch. Intrusion Response Systems: A Survey.
- [14] A. S. Foundations, "Apache http server log files," <http://httpd.apache.org/docs/2.2/logs.html>, Tech. Rep.
- [15] M. Davis, "Unicode technical standard 18, unicode regular expressions," <http://www.unicode.org/unicode/reports/tr18>, Tech. Rep.
- [16] L. Devroye, *Non-Uniform Random Variate Generation*. Springer-Verlag, New York, 1986.
- [17] A. Cardenas, J. Baras, and K. Seamon, "A framework for the evaluation of intrusion detection systems," in *IEEE Symposium on Security and Privacy*. Berkeley/Oakland, California: IEEE Press, 21-24 May 2006.
- [18] G. Gu, P. Fogla, D. Dagon, and W. Lee, "Measuring Intrusion Detection Capability: An Information-Theoretic Approach," in *ACM Symposium of InformAction, Computer and Communications Security (ASIACCS06)*, March 2006.
- [19] M. Almgren, H. Debar, and M. Dacier, "A lightweight tool for detecting web server attacks," in *ISOC Symposium on Network and Distributed Systems Security*, 2000.