

Implementing a Computerized Charge Capture System to Improve Billing Work Flow and Reduce Errors in Data Entry

Chiang S. Jao

Department of Biobehavioral Health Science, University of Illinois, Chicago, IL, USA
Email: csjao@uic.edu

Cathy M. Helgason and Donna A. Zych

Department of Neurology and Rehabilitation, University of Illinois, Chicago, IL, USA
Email: helgason@uic.edu, dzych@uic.edu

Abstract—Background: Traditional paper-based billing operation has experienced a high illegibility error rate and the need for an extended processing time to cope with the billing tasks related to physician reimbursement. We hypothesized that information technology can be adopted to improve the effectiveness of the billing interface, assist in record keeping, and enhance financial outcomes of clinical practice.

Methods: A computerized charge capture system was designed and deployed to test our hypothesis that information technology could reduce illegibility during data entry and improve patient record keeping and billing work flow.

Results: Physicians found that electronic juxtaposition of the pilot system with the electronic medical record was helpful in patient data verification from the progress note. The pilot system was successfully designed to assist physicians in improving information access, and to reduce significant illegibility errors during data entry.

Conclusion: Although overall technical improvements may provide access to desired information, major barriers to data entry and flawed health plan management systems still hamper the efficient implementation and financial outcomes of the adoption of clinical information systems in this time-pressured environment.

Index Terms—Clinical decision support, information technology, electronic charge capture, behavior change.

I. INTRODUCTION

A. Issues Faced in Health Care

Accurate and complete clinical documentation is essential to yielding higher quality of care and obtaining reimbursement for clinical services in the U.S. The American Hospital Association reported that physicians and hospitals have coped with the growing burden in administrative paperwork to comply with regulatory requirements [1]. The Centers for Medicare and Medicaid Services announced that the quality-reporting requirements for hospitals under its final regulations will be expanded for the 2007 hospital outpatient prospective

payment system [2]. According to the proposed regulations, the Medicare rates to hospital outpatient departments are expected to rise by an average of 3%, but the physician reimbursements will be cut by approximately 10% effective July 1, 2008. A 2007 survey comparing adults' health care experiences in seven developed countries including the U.S. indicated that the U.S. stands out for cost-related access barriers and less efficient care [3].

B. The Use of Health Information Systems in Health Care

While coding and billing patient visits consume a large amount of the physician's time, health information systems (HIS) have been historically successful in the area of charge capture, providing the benefits of speedy processing and fast cycling from charge capture to billing [4],[5]. Direct physician use of HIS is vital to incorporating clinical decision support and computer-assisted patient care management into traditional administrative functions such as charge capture and billing [6],[7]. Capture of clinical data and its use for decision making are mandatory at the point of service [8]. HIS have been comprehensively adopted to assess the quality of care and outcomes, to improve the performance of health care providers, and to support health care information management. Stead et al. proposed five steps to achieving a national health information infrastructure in the U.S. that facilitates the efficient interchange of data [9]. One critical step related to service reimbursement is to provide explicit computer-interpretable reimbursement logic by the payers. It might become practical to pay on billing, freeing up both provider and payer staff from transaction processing for quality improvement work.

Information technology (IT) adoption within the health care community in the U.S. lags behind European counterparts because of heavy reliance on "market-driven individual care systems or physicians investment" [10],[11]. Only about one-tenth of the 112,000 primary care physician offices in the U.S. have converted to

electronic records [10]. A “pay for performance” scheme has been proposed that rewards data capture by adopting IT (only possible with use of an electronic medical record [EMR]) and enables physicians to measure and improve quality in their practices [12]. As physicians struggled to learn the applications of IT to patient care, the effort inevitably led to delays in examining patients. Nicholas Carr points out that in the U.S., “The fragmented health care industry, shielded from competition, has been relatively slow to adopt IT, despite its complex information- and transaction-processing requirements. ... IT continues to hold considerably more potential for providing competitive advantage for health care providers than it does for financial institutions” [13].

IT helped the automation of billing and clerical tasks and trimmed significant administrative tasks and costs by accomplishing the billing process through paperless EMRs [14]-[16]. A 2003 national survey conducted by the Harris Interactive Poll revealed that 79% of 1,837 interviewed physicians included the use of electronic billing systems, compared with 27% of them using EMRs and 24% using clinical decision support systems [17]. This trend reflects physicians' need for and high expectation of electronic billing systems, beyond other HIS applications. A 2006 survey on eight regional health care groups in the U.S. revealed that there was increased interest in the adoption of IT to improve the quality of care; significant adoption challenges remained primarily in the area of EMRs and physician-patient communication [18].

II. BACKGROUND OF ONGOING ISSUES

A. The Implementation of Paper-based Billing Systems in the Clinical Setting

The University of Illinois Medical Center at Chicago (UIMCC) is a tertiary care university medical center. UIMCC has implemented a comprehensive, paperless EMR since 1996. Full remote access to the EMR has been extended to several UIMCC community-based sites through commercial Internet connections. It led UIMCC to be named among the top 100 “Most Wired Hospitals” for 2006 in the U.S. by *Hospitals & Health Networks* magazine. After implementing EMR during these years, three goals had been successfully fulfilled: reducing supply costs, receiving reimbursement benefits, and achieving revenue enhancements. UIMCC has adopted the Epic billing system to administer patient care services.

In the Department of Neurology and Rehabilitation at the University of Illinois Hospital (UIH), a double-sided billing slip book is distributed to attending physicians to record their patient care service charges in the inpatient units. On each billing slip, the patient's demographic information (including patient's name, medical record number, date of birth, admission date, gender and race) are either stamped at the nurse's stations or manually filled in by physicians. Other required information that physicians need to provide includes clinical diagnoses (coded with ICD-9-CM Nomenclature, or International

Statistical Classification of Diseases and Related Health Problems, Ninth Revision, Clinical Modification [19]) and the procedures (coded with CPT, or the Current Procedure Terminology [20]) designed on a daily service basis for one-month needs. Physicians are requested to submit their billing slips every two weeks to the billing coordinator, who prepares the reports for the billing service agency.

B. Bottlenecks Faced to Boosting Physician Reimbursements

Current paper slip implementation has historically needed an extended processing time for both physicians and the billing coordinator to deal with charge capture tasks related to physician reimbursements for patient care services. Such delays have significantly weakened the financial outcomes from hospital inpatient and outpatient practices. The observation has been that physicians were reluctant to fill out the slips because of their burden of busy clinical services. Three major bottlenecks have been identified to delaying the charge capture work flow: (1) illegible handwritten data on the billing slips, with as much as a 75% error rate, and the need to rewrite new billing slips by either the billing coordinator or the physician in order to report the accurate and complete information to the billing agency; (2) incomplete progress notes on UIH's EMR that were identified by the billing coordinator did not match up to those procedures documented on the slips; and (3) the manual verification process was time-consuming and flawed. The limited space (6.5 inches by 4 inches) of the paper slip apparently is too small for the needed information (ICD-9-CM codes and CPT codes) required by individual physicians. We redesigned the work flow logic in order to eliminate the bottlenecks. Meanwhile, we investigated (1) the feasibility of a “paperless” work flow, in which physicians submit the charge capture information electronically by filling in an online data entry form available on the UIMCC Intranet Web site, and (2) practical challenges facing the electronic implementation. We hypothesized that IT can be adopted to improve the effectiveness of the billing interface, assist in record keeping, and ultimately enhance financial outcomes of the practice in the neurology and rehabilitation services.

III. METHODS

A. Design Considerations of the Intranet-Based System

The Internet approach to application development has already been recognized with its widespread accessibility. The Intranet implementation is highly demanded because of its well-known advantages; such as: low cost of connectivity, ease of rapid deployment of new technology, use of cross industrial standards, user-friendliness, the ability to extend the value of legacy systems, etc. [21]. Despite electronic data entry systems demonstrating their superiority over paper-based rivals [22], many physicians still had to invest substantial additional time to make needed changes or even bore a much greater time burden after initial system

implementation [23]. The UIH offers an Intranet Web site for health care providers to access various remote clinical administrative applications (including patient care system, patient management, and other clinical and financial information management applications). This heterogeneous environment offers a useful system platform for deploying the HIS to test our hypothesis. We conducted socio-technical requirement analysis by examining the current use of a paper-based billing collection system in an inpatient service unit and identified two socio-technical requirements, awareness and coordination between physicians and billing coordinator, embedded in the billing report task.

B. System Design

In order to make the smooth transition from the paper-based setting to the Intranet-based charge capture system, we proposed the concurrent implementation of two work flow logics. We distributed mass e-mails to all attending physicians in neurology and rehabilitation services to investigate their individual preference and specific requirements of the new system. Traditional paper-based implementation requires physicians to fill in the slip based on their memory of a patient’s diagnostic/procedural information and drop the completed slips in the mailbox of the billing coordinator personally. The billing coordinator conducted the error-checking procedures manually by comparing the data on the slip with the electronic patient chart. If an error was found on the slip, it was returned to the physician for correction. Since there was a high illegibility rate of the handwritten data made by physicians, error-checking procedures were time-consuming for the billing coordinator and delayed the overall work flow for service reimbursement.

The Intranet-based implementation simulated the paper-based work flow logic, improved its procedures, and was designed to save the user’s time in a paperless environment. The use of the keyboard substantially solved the illegibility issue that primarily caused errors. Deploying the HIS on the Intranet Web site facilitates the users checking the electronic progress notes simultaneously and reduces possible risks of patient data inconsistency. The use of e-mails allows information exchange between physicians and the billing coordinator. Fig. 1 illustrates the parallel implementation of the billing work flow with both the paper slip and an integrated HIS based on the UIH Intranet.

To assist physicians in submitting their service charge data efficiently and effectively, we set out to design an electronic Charge Transmittal Form, a clinical information system based on Microsoft Access®, which introduces an empirical approach to a semi-automated “paperless” work flow. The electronic form contains a patient charge capture data repository and a user-friendly interface which is enhanced by Microsoft Visual Basic® programming language. The electronic data entry form includes two user portals: one for physicians, designed with the personalized information for the physician’s need of individual specialty and patient treatment, and another for the billing coordinator to group electronic

billing reports by service types for the use of charge reporting. The electronic form retains the layout of the original paper slip, and takes advantages of several Windows features to manage the work flow more intelligently. The interface was designed not only to reduce keystrokes in a number of data attributes that can be preprinted on the screen in advance by the system, but also to improve the legibility of input data (discussed in the next section).

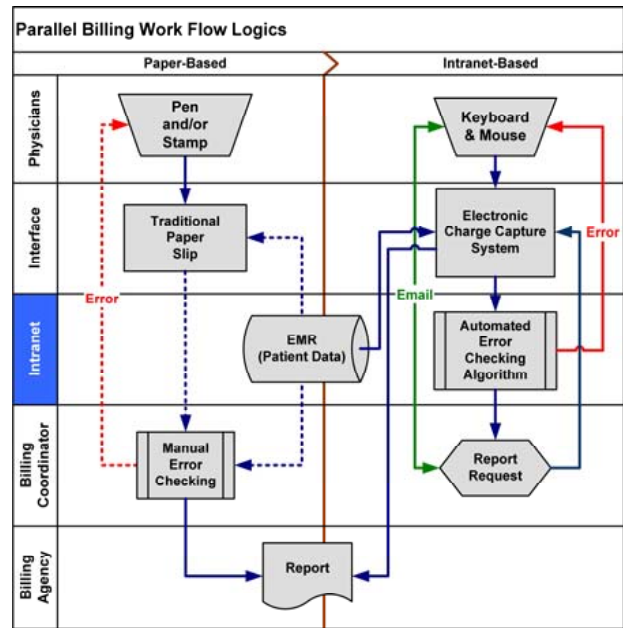

Figure 1. Parallel implementation of the traditional paper-based slip-book and the Intranet-based HIS. The dash lines represent the indirect access of the process under the same user platform.

C. Interface Design

The user interface of the electronic form, shown in Fig. 2, offers hyperlinks to connect several open online resources (online ICD-9-CM code search [24]-[25] and online CPT code search [26]) as ancillary reference tools, and the user can add extra codes not included in existing code pick lists. Since the electronic form is working in juxtaposition with UIH’s EMR, it provides a quick start to physicians and the billing coordinator in accessing the progress notes on UIH’s EMR and verifying the consistency of documented diagnoses and procedures ordered on the notes. To avoid illegible data, as well as the need for more keystrokes, physicians can copy the complete patient data from UIH’s EMR and paste them onto the electronic form. However, the electronic form lacks direct interfaces to the EMR and the Epic billing system. Physicians need to add new patient data manually into the patient repository. These system setups were configured to eliminate the bottlenecks discussed in the previous section.

Physicians were asked to mark the “complete” checkbox on each completed case, and the system automatically counted and displayed the number of all completed cases for statistical use. A sign-in log, linked to the online form, provides record keeping capability to

share the information between the service physicians and the billing coordinator about the number and dates of completed charge cases. This was equivalent to tearing out the paper slip from the billing booklet and putting it into the mailbox of the billing coordinator. In the meantime, users were requested to send a notice electronically to the billing coordinator to confirm the completeness of their electronic submission.

The system uses the decision support algorithm to reduce system variance from individual needs, and the machine learning algorithms are used to enhance system performance, including (1) the capabilities of data search and duplication from the patient repository without repeated entry; (2) automatic fine-tuning of the code pick lists of available diagnoses and procedures derived from the service type. The new operation was implemented in a paperless and semi-automated work flow. The pilot system was designed to assist physicians to improve the work flow by streamlining administrative charge capture tasks, and to reduce the likelihood of illegible data and time spent in data verification.

D. Database Query and Data Extraction

A database query was designed to provide appropriate data to the user during a data query. The relationship of columns in the database is displayed as a tabulated form to the user. When the user selects a column in the database, a filtered display mechanism displays those columns that satisfy the portion of the query already constructed. The SQL query [27] was adopted to retrieve tabulated data from the knowledge base after the user selected an appropriate item from the dropdown pick list as shown in Fig. 2; for example, the clinical diagnosis “Intracerebral hemorrhage” will be displayed after selecting an ICD-9-CM code “431,” and vice versa.

We imitated the diagnosis/procedure selection process by applying the query onto the relational database. This yields a set of available diagnoses or procedures that can be extracted from the database as a group of qualified items that would be eligible for the patient’s state. This model includes user queries, performs syntactic processing to transform the input to a canonical form, selects the appropriate clinical terms to answer the query, and displays results. This approach is based on metadata supporting a query front end that essentially hides the entity-attribute-value nature of individual attributes from the user. It saves the user significant time on keystrokes of complicated medical terms and reduces the possibility of entering erroneous data.

E. Algorithmic Inference Model

In this project, a rule-based knowledge inference model is used to reason about terminology and required domain knowledge. Inference is algorithmic and useful to perform since the inferences apply to all patients under appropriate billing circumstances. An algorithm was developed to assist translation of the relationships of medical diagnoses/treatment and their associated clinical vocabulary into decision rules for an inference engine. Each inference rule was aligned with the clinical specialties and triggered to link appropriate treatment

procedures to a specific billing code for individual physicians under the guidelines of the billing agency. We also adopted data mining and machine learning algorithms to improve billing code representations of medical diagnosis and treatment when physicians added new items into the knowledge base.

The association rules algorithm was applied to assist the user in extracting a specified medical record from the patient data repository, duplicating patients’ demographic information from the patient data repository as new follow-up records, and controlling the display of completed and uncompleted records for record maintenance and report preparation. This approach facilitates patient record keeping and information extraction from the patient data repository. In Fig. 3, a data extraction process was manipulated to extract from the patient data repository only the attributes to which the association rules algorithm would be applied.

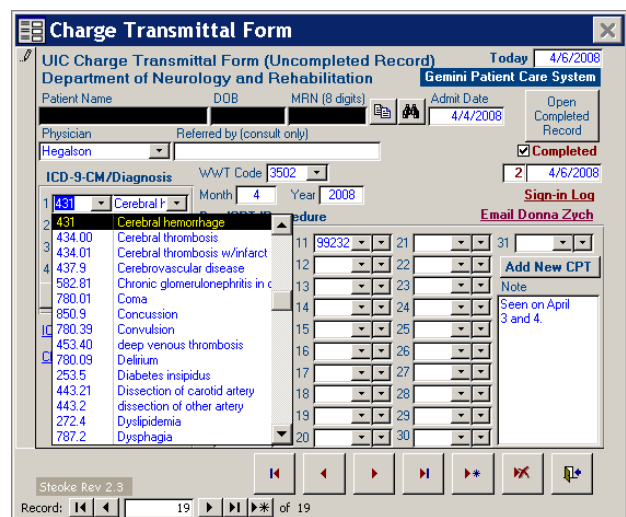

Figure 2. The user interface of the electronic charge transmittal form assists physicians in improving productivity by streamlining administrative tasks and the work flow for their service charge submission.

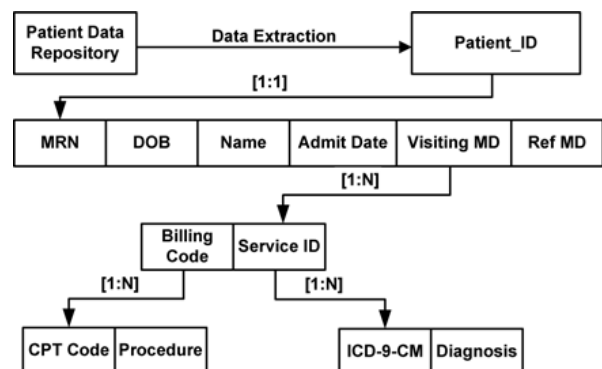

Figure 3. Data extraction process applied in the association rules algorithm.

F. Data Collection and Analysis

For data collection, we used direct observation, surveys and interviews as the principal sources of data.

We used open-ended questions and asked respondents to describe the implementation, from project initiation to implementation. Interviews lasted approximately 30 minutes on average. Data gathered through observation and interviews were used to validate and complement the survey data.

IV. RESULTS

The electronic implementation for service charge capture is optional to use for attending physicians while the billing slip books continue to be distributed to them. Nine physicians participated in the training session in using the electronic form, and five of them (55%) decided to adopt it after six-month implementation. Two years after introducing this pilot system, four physicians are still using it.

A. User Survey

After the six-month implementation, an online survey was distributed to all users to collect feedback. We collected 6 anonymously completed surveys (67% response rate). User feedback showed high preference for this pilot form because of its ease of use and submitting bills electronically, online accessibility to the remote ICD-9-CM and CPT coding Web sites to add new diagnoses and procedures effectively, the paperless work flow, a clear user interface arrangement, and more accurate and legible data displayed on the screen. The pros and cons from the users in using the paper slip books and the electronic charge capture system are summarized in Table I. In addition, users strongly expressed the desire to transfer the information entry in the pilot system into orders in the EMR. Users also were concerned about the inaccessibility of the pilot system during the system downtime and worried about the possibility of data loss during the entry time. The results from the survey revealed that experience with an IT-based system was the preferred way to overcome attitudinal barriers to adopting HIS. The users commented that the design of the electronic billing implementation was an “excellent trial system” with “lots of nice enhancements.”

B. Physician Interviews and Behavioral Observation

From physician interviews and behavioral observation, physicians agreed that electronic juxtaposition of the pilot system with the EMR was helpful and anecdotally reported that the new system has helped patient data verification from the progress note. Physicians previously had felt comfortable with the use of paper slips because of their familiarity and the portability of paper slip books at the point of care. However, comments were made about the incompleteness and inaccuracy of patient information on the pilot system, which often required users to enter the patient demographical data manually. This phenomenon was repeated in both paper and electronic implementations because of the physician’s long-standing habit. Users reported that the pilot system did not help save significant time in data entry.

C. Handheld Implementation?

Since the pilot system lacked appropriate interfaces to connect to UIH’s EMR and the Epic billing system, the departmental steering committee was investigating an alternative method by incorporating handheld billing implementation on personal digital assistants in the near future. Previous handheld implementation of patient charge capture systems has been shown to be efficacious and usable in both the inpatient setting and the long-term care setting, compared to an established paper process [28]-[30]. PDA has been effective in its portability of practice guidelines and alerting reminders [31]-[33]. Mitchell and Saulich showed that the handheld charge capture system could enable generation of more charges and have real-time reconciliation capabilities for providing timely follow-up [34]. It will be our next task to incorporate the decision support strategy into the PDA implementation to improve overall billing work flow.

TABLE I.
STRENGTH AND WEAKNESS OF PAPER-BASED AND IT-BASED IMPLEMENTATION

Paper Slip Book	
<i>Pros</i>	<ul style="list-style-type: none"> • Less likely to lose billing book • Ease of carrying into clinical units
<i>Cons</i>	<ul style="list-style-type: none"> • Illegibility issue • Data entry requirements • Lack of interface to UIH’s EMR • Lack of interface to Epic Billing System
Electronic Charge Capture System	
<i>Pros</i>	<ul style="list-style-type: none"> • More legible • More accurate • Clearer format • Easy links to external code access • Interface to UIH’s EMR
<i>Cons</i>	<ul style="list-style-type: none"> • Cannot save time by entering data • Cannot transfer demographic data from UIH’s EMR • Not faster to fill out than paper

V. DISCUSSION

A. Work Flow Changes

This pilot system was a very practical tool in assessing both the new application and its impact on billing work flow. It has clearly demonstrated the potential of an IT-based application for improving the charge capture work flow. Morgan [35] depicted the importance of the work flow change as the first step to promoting the use of high-performance health systems for health care. Experience from this pilot study suggests the following factors for promoting acceptance and use of HIS by physicians: (1) it is critical to gain broad physician involvement in system design and implementation from the beginning, including support from physicians influential to other members in the use of the system; (2) it is essential to assess the impact of a new system on routine practice patterns before introducing it, especially the time spent in

adopting it; (3) the organization should be ready to manage behavioral and organizational changes caused by the introduction of the new system; (4) one or more physician champions is necessary to drive the physician adoption of a new system. Further cultural and organizational changes are needed for real improvement so that the value of IT can be fully realized in patient care. A balance between physician autonomy and accountability would be a practical challenge for physicians to adopting IT.

Comparing the paper slips with the electronic charge capture system, the latter offers a better routine for reducing illegibility, while the former is familiar but primitive. System security issues were not the major concern in this study since UIH has provided a secured site for system implementation. User feedback revealed that their unfamiliarity with emerging IT reduces their willingness to adopt a new IT-based application, including the impending handheld billing approach. The system downtime raises concerns and reduces the expectations of an IT-based system. Changes in physicians' computer anxiety and attitudes related to CIS use will be major challenges facing IT implementation in the long term.

Our intent in developing and implementing the electronic charge capture system with its automated error-checking capability was to improve documentation illegibility and billing performance while easing the burden of documentation on physicians. However, we recognized that attending physicians might find the data entry feature to be a nuisance when they felt more comfortable with the pen and paper beyond the keyboard and mouse. The results from user surveys and interviews suggested that frequent use of IT gained higher acceptance. Timely user training and support is essential to demonstrating an ongoing organizational commitment to work flow improvement.

B. Challenges on User Adaptation

The pilot study revealed that getting physician approval is essential to the success of an IT-based initiative. Even though the user interface was sufficiently easy for data entry by reducing keystrokes, users expected to reduce more of their time in data entry. Integration of the pilot system into the EMR and the Epic billing system can break down the barrier in data entry. In further development, it would be another challenge to improve the data entry limitation in order to promote the acceptance rate and to ensure a broad outreach to draw potential users for a new IT-based application.

Our observation concluded that (1) the likelihood of physicians' resistance from their previous negative experiences with IT can lead to the rejection of new IT systems, even though IT is user-friendly; (2) the management commitment to the new IT system is an important predictor of the success of physicians' behavioral changes; and (3) continuous practice with the new IT system will extend its use as well as the adoption of IT into daily tasks.

The anecdotal data suggest that the current system may be inadequate. Some errors, previously identified on the

paper slips, were repeated in the electronic implementation. These errors related to the correctness and completeness of patient information on the form. Even though IT helps to reduce errors, the proper use of HIS is critical in error reduction. A number of efforts need to be made to increase the visibility and magnitude of this issue faced by physicians. Changes in physician behavior related to correct data entry will take account of the ongoing challenges in system implementation. Two years after introducing this Intranet-based charge capture system, four attending physicians remain users who prefer the electronic implementation over paper slip books.

C. Limitations

This study has a number of limitations. First, this pilot study was limited to a small-scale implementation and lacked sufficient sample size to justify its usefulness. Possible participant bias and observer errors may affect the results in this study. It needed to gather a larger size of samples and collect more evidence to conduct the judgment analysis in quality research. Second, lack of direct interfaces to the EMR and the Epic system in UIH restricts the ease of data entry of patient information by physicians. Third, a possible Hawthorne effect needs to be carefully considered in the design of HIS to promote physician productivity on a sustainable and long-term basis. Fourth, possible errors generated by IT could have existed in HIS and should be prevented in advance, as studied by Bates et al. [36]. Fifth, the absence of physician champions to push forward the adoption of new IT systems restricts broad physician adoption.

D. Flawed Billing Management System

Even though IT assists in patient record keeping and work flow improvement, financial outcomes did not reflect these advantages because of the faulty health coverage and management systems in the U.S. Processing errors from a number of managed health plan organizations (including Medicaid, Medicare, and Health Management Organization) diminished our efforts in deploying the electronic charge capture system for work flow enhancement: for example, serious processing delays from the agencies in physician reimbursement for clinical services, slow responses on the request of updating physician information, the mismatch of patient information, etc. Deterioration of financial revenues from physician reimbursement was significantly affected by flawed processes in the managed health plan organizations.

VI. CONCLUSION

The implementation of HIS imposes a change of traditional practice patterns for physicians. The HIS help our physicians improve the administrative charge capture tasks, eliminate accessible barriers, and prevent illegibility errors. Improved data entry implementation facilitates the work flow in routine use, as desired. The electronic paperless setting eliminates the administrative time and cost involving finding, pulling, and filing paper

billing slips. The paperless system delivers easy access to printable or exportable data for those who need to analyze practice patterns. We can routinely use results to educate physicians and modulate changes within the practice effectively.

IT alone has little effect in solving problems in billing work flow. IT will be effectively fit only if:

- the need is fully investigated and well defined;
- those stakeholders involved are truly dedicated to creating the solution;
- the tool is carefully built or tailored based upon the real environment utilization and work flow;
- the need for a full organizational commitment and investment from the administration is essential to validating the use of the tool.

The challenges facing implementation of the IT-based application draw a clear picture for designing useful HIS to meet physicians' needs. Although overall technical improvement in access to desired information was obtained, major barriers on data entry still hamper the efficient implementation and adoption of HIS. HIS should be designed and adopted in an easier and more practical approach, to assist physicians in preventing latent errors, removing preexisting barriers, and expediting data entry time in this time-pressured environment. Faulty billing management systems from Medicaid and Medicare offset the effort in IT adoption and need to be improved. It is crucial to communicate easily with physicians in order to promote their acceptance of HIS. Even though HIS are not a panacea to solve all issues in the health care community, they can play an influential role in reducing administrative cost, assisting in record keeping, preventing potential errors in data entry, and promoting patient safety eventually.

ACKNOWLEDGMENT

The authors thank Dr. John R. Hughes for providing valuable comment on this manuscript. The authors thank Kevin Grandfield for editorial assistance.

REFERENCES

[1] American Hospital Association, *Patients or paperwork? The regulatory burden facing America's hospitals*, 2001, www.aha.org/aha/content/2001/pdf/FinalPaperworkReport.pdf

[2] Modern Healthcare Online. *CMS changes quality reporting plan*, November 1, 2006, <http://modernhealthcare.com/apps/pbcs.dll/article?AID=/20061101/REG/61101013>

[3] C. Schoen, R. Osborn, M. M. Doty, M. Bishop, J. Peugh, and N. Murukutla, "Toward higher-performance health systems: Adults' health care experiences in seven countries," *Health Aff*, vol. 26, pp. w717-w734, 2007.

[4] H. L. Bleich, C. Safran, and W. V. Slack, "Departmental and laboratory computing in two hospitals," *M.D. Computing*, vol. 6, pp. 149-155, 1989.

[5] D. N. Mohr, "Benefits of an electronic clinical information system," *Health Inf Manage*, vol. 11, pp. 49-57, 1997.

[6] J. G. Anderson, "Clearing the way for physicians' use of clinical information systems," *Comm ACM*, vol. 40, pp. 83-90, 1997.

[7] W. W. Stead, R. A. Miller, M. A. Musen, and W. R. Hersh, "Integration and beyond: Linking information from disparate sources and into workflow," *J Am Med Inform Assoc*, vol 7, pp. 135-145, 2000.

[8] D. L. Reich, R. A. Kahn, D. Wax, T. Palvia, M. Galati, and M. Krol, "Development of a module for point-of-care charge capture and submission using an anesthesia information management system," *Anesthesiology*, vol. 105, 179-186, 2006.

[9] W. W. Stead, B. J. Kelly, and R. M. Kolodner, "Achievable steps toward building a National Health Information infrastructure in the United States," *J Am Med Inform Assoc*, vol. 12, pp. 113-120, Mar-Apr 2005.

[10] R. N. Charette, "Dying for data," *IEEE Spectrum*, vol. 43, pp. 22-27, Oct 2006.

[11] C. Means, "U.S. lags behind in primary care IT, survey finds," *Healthcare IT News*, Internet Exclusive, 2006, <http://www.healthcareitnews.com/story.cms?id=5854>.

[12] M. L. Millenson, "Pay for performance: the best worst choice," *Qual Saf Health Care*, vol. 13, pp. 323-324, Oct 2004.

[13] N. G. Carr, *Does IT matter? Information technology and the corrosion of competitive advantage*, Harvard Business School Press, Cambridge, MA, p.67, 2003.

[14] S. Woolhandler, T. Campbell, and D. U. Himmelstein, "Costs of health care administration in the U.S. and Canada," *N Engl J Med*, vol. 349, pp. 768-775, 2003.

[15] S. F. Spring, W. S. Sandberg, S. Anupama, J. L. Walsh, W. D. Driscoll, and D. E. Raines, "Automated documentation error detection and notification improves anesthesia billing performance," *Anesthesiology*. Vol. 106, pp. 157-163, Jan 2007.

[16] C. W. Burt, and E. Hing, "Use of computerized clinical support systems in medical settings: United States, 2001-03," *Adv Data*. Vol. 2, no. 353, pp. 1-8, Mar 2005.

[17] Harris Interactive, *The Commonwealth Fund 2003 National Survey of Physicians and Quality of Care*, March 17-May 30, 2003. Available http://www.cmf.org/surveys/surveys_show.htm?doc_id=278869.

[18] E. G. Poon, A. K. Jha, M. Christino, M. M. Honour, R. Fernandopulle, B. Middleton, J. Newhouse, L. Leape, D. W. Bates, D. Blumenthal, and R. Kaushal, "Assessing the level of healthcare information technology adoption in the United States: a snapshot," *BMC Med Inform Decis Mak*, vol. 6, Jan 2006. <http://www.biomedcentral.com/content/pdf/1472-6947-6-1.pdf>.

[19] National Center for Health Statistics, "International Classification of Diseases, Ninth Revision, Clinical Modification (ICD-9-CM)," <http://www.cdc.gov/nchs/about/otheract/icd9/>.

[20] American Medical Association, CPT® (Current Procedural Terminology), <http://www.ama-assn.org/ama/pub/category/3113.html>.

[21] K. Siau, "Health care informatics," *IEEE Trans Inform Tech in Biomed*, vol. 7, pp. 1-7, Mar 2003.

[22] S. N. Luxenberg, D. D. DuBois, C. G. Fraley, R. R. Hamburg, X. L. Huang, and P. D. Clayton, "Electronic forms: benefits and drawbacks of a World Wide Web-based approach to data entry," *Proc AMIA Annu Fall Symp*, pp. 804-808, 1997.

[23] R. H. Miller, and I. Sim, "Physicians' use of electronic medical records: barriers and solutions," *Health Aff*, vol. 23, pp. 116-26, Mar-Apr 2004.

[24] Online ICD9/ICD9CM Codes, <http://icd9cm.chrisendres.com>.

[25] ICD9Ddata.com – Free 2007 ICD-9-CM Code Database, <http://www.icd9data.com>.

- [26] American Medical Association, CPT Search, https://catalog.ama-assn.org/Catalog/cpt/cpt_search.jsp?locality=IL
- [27] T. M. Connolly, and C. E. Begg, *Database systems: A practical approach to design, implementation, and management*, Addison-Wesley, NY, 2005.
- [28] S. M. Strayer, "Study evaluating handheld computer software to increase inpatient billing charge capture," *J Am Med Inform Assoc*, Suppl. 5, p. 837, 2001.
- [29] K. M. Morrison, "Coding and billing software for palm-top computers: Your PDA can help you code more efficiently and accurately," *Family Practice Management*, pp. 33-37, 2002.
- [30] S. M. Handler, V. C. Hsieh, D. A. Nace, L. Sciulli, D. B. Fridsma, and S. A. Studenski, Development and evaluation of a charge capture program for long-term care providers, *J Am Med Dir Assoc*, vol. 5, pp. 337-341, 2004.
- [31] C. S. Jao, D. B. Hier, J. Su, "Evaluating a digital Resident Diagnosis Log: reasons for limited acceptance of a PDA solution," *AMIA Annu Symp Proc*, p. 876, 2003.
- [32] C. S. Jao, W. Doller, J. Su, "Porting a handheld cognitive assessment form to a mental expert system. Using a personal digital assistant (PDA) to assess screening a patient's performance in a clinical examination," *Neuroinformatics*, vol. 1, pp. 203-206, 2003.
- [33] J.M. Rothschild, E. Fang, V. Liu, I. Litvak, C. Yoon, D. W. Bates, "Use and perceived benefits of handheld computer-based clinical references," *J Am Med Inform Assoc*, vol. 13, 619-626, Nov-Dec 2006.
- [34] D. Mitchell, M. J. Saulich. "Breaking the code," *Health Financ Manage*, vol. 59, pp. 44-46, 48, Dec 2006.
- [35] J. J. Morgan, *Framework for a high performance health system for the U.S.*, presented at 2006 American Medical Informatics Association Symposium, Washington, D.C., Nov. 13, 2006
- [36] D. W. Bates, M. Cohen, L. L. Leape, J. M. Overhage, M. M. Shabot, and T. Sheridan, "Reducing the frequency of errors in medicine using information technology," *J Am Med Inform Assoc*, vol. 8, pp. 299-308, 2001.

Chiang S. Jao, was born in Taiwan, ROC and now is a U.S. citizen. He completed a Ph.D. degree in computer sciences at Illinois Institute of Technology in 1992 and an Illinois Board of Higher Education Professional Certificate in health informatics at the University of Illinois at Chicago (UIC) in 2005.

He was on the faculty of the Department of Neurology and Rehabilitation between 1992 and 2007, and now is Research Assistant Professor in the Department of Biobehavioral Health Science at UIC. He has published several scientific papers in health information systems, patient safety and user interface design. His research interests include clinical decision support, medical database management, and human-system interface design. He owns the copyrights of two novel health information systems.

Dr. Jao is an active member of the Institute of Electrical and Electronics Engineers, American Medical Informatics Association, the Association for Computer Machinery and American Academy of Sleep Medicine. He was awarded honorable mention for the 1991 IEEE Student Applied Expert System Competition, Year 2000 Best Medical Education Program at UIC Medical School, and Year 2001 Best General Neurology Web Site Design sponsored by MDWEB.COM.

Cathy M. Helgason, was born in Chicago and studied at the University of Chicago, completing her residency in Neurology and Fellowship at Michael Reese Hospital under the mentorship of Dr. Louis R Caplan. She has been a faculty member at the University of Illinois College of Medicine at Chicago since 1985 in the Department of Neurology as Director of the Cerebrovascular Service. She is currently full Professor of Neurology. Her research interests have focused on anti thrombotic therapy and stroke and most recently on the application of fuzzy theory to medical diagnosis and treatment. She is a member of the American Neurological Association and IEEE SMC society. She is an active member of the North American Fuzzy Information Processing Society and IEEE Systems Man and Cybernetics Society..

Donna A. Zych, is the billing coordinator of the Department of Neurology and Rehabilitation Medicine at the University of Illinois at Chicago.