

Statistical Analysis of Broadband Wireless Links in Rural Areas

Wei Zhan and Ana E. Goulart

Texas A&M University/Department of Engineering Technology and Industrial Distribution, College Station, TX, USA

Email: {zhan, goulart}@entc.tamu.edu

Abstract— Third-generation (3G) cellular systems are often considered as a promising strategy for high-speed internet deployment in rural areas. However, bandwidth in 3G systems is a limited resource and can be quite different from the advertised bandwidth. In addition, in wireless applications such as voice over IP, video-conference, remote monitoring and telemetry (e.g., for healthcare applications) the Quality of Service (QoS) is critical. It is therefore important to understand how different factors affect the QoS requirements of real-time applications. Focusing on the reverse link (or uplink), we performed an assessment of the bandwidth and packet loss rate in a real network environment, using test data collected with two wireless data cards from different providers, in both rural and urban locations. The main contribution of this paper is the presentation of a formal statistical method – a Design of Experiments (DOE) analysis - that can be used to analyze the interactions between different variables, such as packet size, location, buffer size, and wireless provider. With a better understanding of the impact of such factors and their interactions, the end-user may be able to make the best selection of certain controllable parameters, in an effort to improve the QoS of the 3G connection. This is especially important for users located in rural areas, where cellular coverage is limited.

Index Terms—statistical analysis, design of experiments, broadband wireless, 3G, QoS, real-time traffic.

I. INTRODUCTION

Third-generation (3G) cellular systems are often considered as a promising way of rapidly deploying high speed data services to stationary users in rural and remote areas [1]. For example, stationary users can be mobile clinics, internet kiosks, or residential users.

There are two main 3G technologies that provide dedicated data services: High Speed Packet Access (HSPA) and 1xEV-DO. HSPA is the high speed data services of the Universal Mobile Telecommunication Systems (UMTS) standard which uses Wideband-CDMA technology. 1xEV-DO is based on CDMA/High Data Rate technology [2], which is a packet standard used with IS-95 and cdma2000 networks. This technology is also known as an evolutionary advancement for CDMA, and when used for “data only” is called EV-DO. Sometimes these technologies are referred to as 3.5G.

In packet data cellular systems, such as 1x-EV-DO, the

peak (and typically advertised) bandwidth is 2.4Mbps. However, the actual bandwidth experienced by the end-user depends on several factors: (i) the location of the user or subscriber, which impacts the signal quality at the wireless device, (ii) the wireless equipment and its “adaptive” techniques (modulation and encoding schemes), (iii) the number of users in the wireless network, (iv) the overall congestion and latency in the wired backbone. From the end-user viewpoint, these factors are unknown or cannot be directly measured. In fact, typical performance is in the lower hundreds of kbps.

Moreover, these 3G wireless systems were designed for client-server Internet applications, such as web browsing and file transfer. Thus, the forward and reverse links were designed to provide asymmetric data rates, with the bandwidth in the forward (i.e., downlink) higher than in the reverse links (i.e., uplink). According to [2], one can expect the downlink capacity to be three or four times greater than the uplink capacity for data only applications.

How would real-time applications (such as voice over IP, video conference, remote monitoring and telemetry) perform in this dynamically changing and often unreliable broadband wireless network? Is the performance of the reverse link satisfactory? What is the impact of variables such as packet size, buffer size, data streaming rate, location of the end-user, weather condition, and time of the day?

The main contribution of this paper is to present a formal statistical method – a Design of Experiments (DOE) analysis [3] - that can be used to analyze the interactions between different variables to help us understand their impact on the performance, or Quality of Service (QoS), of a 3G service. This is especially important for users located in rural areas, where the cellular coverage may be poor. Thus, the understanding of how a few factors (usually under the user control) can improve the performance is crucial.

We focus on real-time communications and the flow of data originating from the wireless user. The QoS parameters are throughput and packet loss rate. The variables tested are: wireless provider, location, packet size, and receiver’s buffer size.

DOE analysis was first used in [4] to analyze the impact of relevant variables on QoS of the end-user’s applications. In this paper, we conduct more extensive research, based on additional variables and a larger set of

test data. For instance, we have extended our experiments to different locations, using two different wireless service providers, and covering a more comprehensive range of packet sizes.

The remainder of the paper is organized as follows. In the next section, we provide a background on performance studies of real-time applications using 3G cellular networks. In section III, the experimental setup is described. Section IV discusses the DOE setup and test results. Analysis of the results is presented in Section V, followed by conclusions in Section VI.

II. BACKGROUND

For any given wireless communication system, there are many factors that have impact on the performance of the uplink transmission, such as packet size, buffer size, data streaming rate, location of the end-user, weather condition, and time of day. These variables can all be viewed as inputs to the communication system. However, based on the nature of the parameters they can be divided into two groups: one is the control parameters and the other is the noise parameters. A control parameter is one that can be set to certain value by the end-user. A noise parameter is one that the end-user has no control. The optimization of QoS is to select the control parameters such that for any values of the noise parameters certain objective function involving the uplink throughput and the packet loss rate is maximized.

Our approach to better understand these factors is to use the DOE method, in which certain combinations of extreme cases of each variable are targeted for testing, with each experiment repeated several times. The resulting reverse link throughput and packet loss rate are used to identify the impact of each variable on the uplink transmissions. Furthermore, the DOE method allows us to analyze the interactions between variables.

There are several studies on the performance of real-time applications over 3G systems. However, they covered different aspects, such as downlink transmissions [5, 7], older wireless technologies [5, 6, 7], TCP traffic [8], simulation, or test bed results [9, 10]. Some of the ideas in those papers such as performance evaluation may be similar to what we are trying to do, but there are significant differences. For the uplink transmission of the User Datagram Protocol (UDP), the end-user does not have access to all the information about the network. In our case, the network is like a black box with limited amount of feedback to the end-user. The production network based on CDMA/HDR (High Data Rate) [2] used for the experiments also may have different characteristics compared to other system or simulation models. Finally, our approach allows the evaluation and comparison of simultaneous wireless connections [24].

Mobile Health Systems

In the last decade, Mobile Health systems have attracted increasing attention of researchers and commercial developers [11-18]. For instance, the DREAMs ambulances [19] exchange high-quality video,

vital signs, voice and text communications in real-time with the emergency room using the UDP transport protocol. By taking advantage of the widespread cellular coverage in rural and urban areas, when the patient needs immediate care from a doctor, the ambulance needs to get connectivity on its way to the hospital. The doctor can communicate in audio and video with the emergency medical technicians (EMTs) and has immediate access to the vital signs of the patient.

In wireless applications such as Mobile Health systems, the QoS is critical. It is therefore important to understand how different factors affect QoS (e.g., reliability and delays), which is determined mainly by the uplink transmission characteristics [4]. The performance of an uplink 3G system for Mobile Health application is studied in [14] using the OPNET simulation tool. The impact of buffer size on QoS metrics including jitter and packet loss rate are studied in [17] with real test setup using UMTS. In [20], the problem of optimally selecting the best channel among a pool of channels available to the communication system in the DREAMs ambulance was discussed using modeling and simulation tools. There are other wireless applications such as a mobile clinic [21] and mobile communication systems used by the military [22]. Some of these systems can be stationary or semi-stationary but the location can be different. Given its importance and complexity, the current understanding of the QoS optimization problem for wireless communication systems is far from sufficient.

III. EXPERIMENTAL SETUP

In our DOE analysis, the network is considered as a “black box”. The only known factor from the network is the coverage maps provided by the network provider, as shown in Fig. 1 and Fig. 2. Two different locations and two network providers were used for the DOE testing:

- The first location is in Steep Hollow, Texas. This is a sparsely populated area. This location has poor coverage by Provider 2 and good coverage by Provider 1. Fig. 1 illustrates the coverage map for Provider 2. Table 1 is Provider 2’s the description of service and the average speed for the gray area, where Steep Hollow is located, is between 50 and 70 kbps.

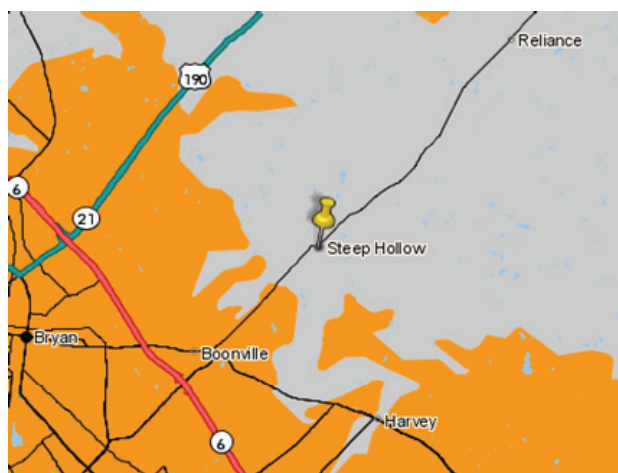

Figure 1. Provider 2’s coverage in Steep Hollow, TX.

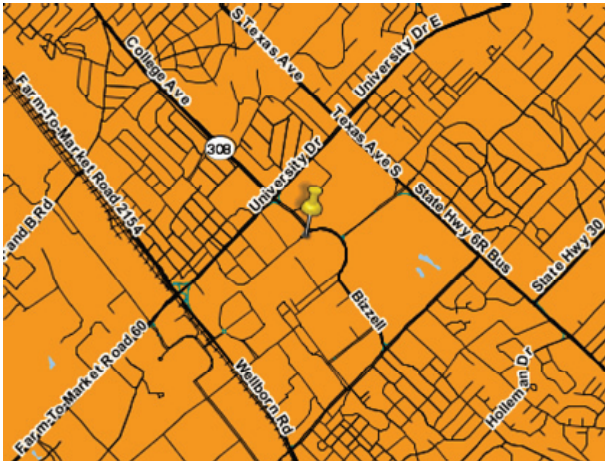

Figure 2. Provider 2's coverage in Fermier Hall, (Texas A&M College Station campus).

TABLE 1. PROVIDER 2'S COVERAGE DETAILS

Coverage	Download Average Speeds	Upload Average Speeds
Mobile broadband network	600 kbps – 1.4 Mbps	350kbps – 500 kbps
Mobile broadband roaming	400kbps – 700kbps	50kbps – 70kbps
Nationwide network	50kbps-70kbps	50kbps-70kbps
Data roaming	50kbps-70kbps	50kbps-70kbps

- The second location is in a good/excellent coverage area for both providers: Fermier Hall on the campus of Texas A&M University. But the tests were conducted in the basement, where wireless access is poor.

The cards used in our tests are a Sierra Wireless AirCard 597A and a KPC680 ExpressCard, both based on CDMA/HDR [4] or EV-DO. The EV-DO systems employ adaptive techniques (such as modulation schemes, forward error correction codes, and packet sizes), thus providing different bandwidth and delays depending on the signal-to-noise ratio (SNR) measured at the mobile user.

The tests were conducted using a network performance tool Iperf [23]. This program runs as a client/server application, over either TCP or UDP transport protocol. To emulate real-time traffic, the experiments are conducted using UDP traffic, at a constant bit rate. Several parameters can be configured when running Iperf over UDP mode: the client can create UDP streams of specified bandwidth, packet length, and the server can be configured with different buffer sizes. The reason for assuming constant bit rate is that we are mainly interested in voice and remote monitoring traffic. In the communication system studied in [20], voice and vital signs monitoring were considered as the highest priority traffic.

As shown in Fig. 3, using the mobile station as the client and a fixed Internet node as the server, the actual bandwidth over a period of 10 minutes was measured in each experiment. Every second, the effective bandwidth the application received and the packet loss rate, calculated as the ratio between the lost packets and the total number of packets sent, were recorded.

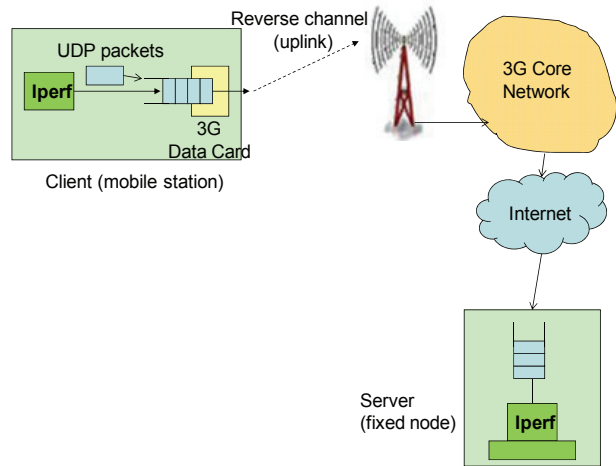

Figure 3. Experimental setup for the assessment of uplink bandwidth and packet loss rate.

IV. DESIGN OF EXPERIMENTS

The initial focus of the experiments was to evaluate the bandwidth and reliability of mobile users, such as the DREAMS ambulance [19]. However, it was found that the results for moving mobile units were very random and difficult to analyze. Fig. 4 shows the throughput (in kbps) and packet loss rate (in percent) results of an experiment conducted on a mobile test unit while traveling at 40 mph speed. It is clear that as the mobile test unit moves along the route, the QoS changes considerably. Additional tests on a mobile unit with different route and speed suggested that tests with the mobile unit moving have dependency on the route and speed and the results are highly unpredictable. In order to perform the DOE analysis effectively, the location of the mobile unit will be fixed. Same DOE tests will be repeated at different locations.

Another relevant but difficult to control variable is the weather condition. Raining, overcast, and clear are the basic types of weather. But only the clear weather is a consistent test condition. All experiments will be conducted under clear weather and similar temperature and humidity conditions to minimize the impact of the uncontrollable weather condition on the test results.

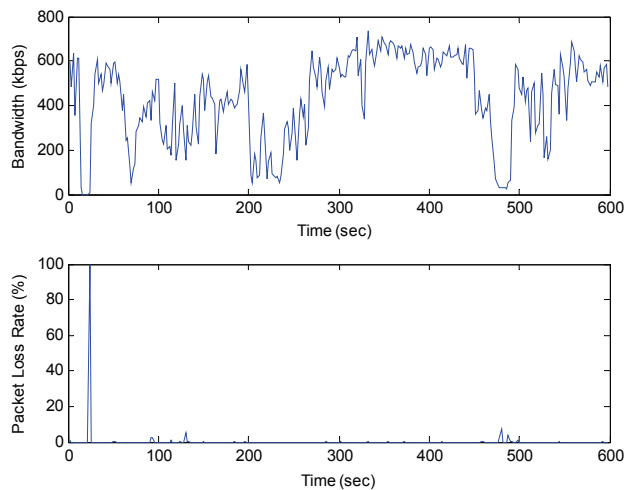

Figure 4. Sample throughput and packet loss rate for a mobile user.

The same test equipment is used to avoid the contribution of equipment and its interaction with other variables to the test results.

The initial research in [4] included data streaming rate as an independent variable in the DOE matrix. This is correct but the comparison of the bandwidths for different data streaming rates would not be fair since the lower bandwidth could be a result of the user requesting less data to be transferred instead of what the system is capable of doing. Therefore, in this paper the DOE will not include data streaming rate as a variable in the DOE matrix. Instead, a constant value of 500 kbps will be used for data streaming rate. The DOE analysis in [4] also concluded that the impact of time of the day is insignificant. During the test conducted in preparation for the publication of [4], we also noticed that the relationship between QoS and the packet size may be highly nonlinear. Therefore, more than two levels for this variable were tested to reveal more information.

Based on the above considerations, the DOE analysis is limited to two variables: packet size (3 levels) and buffer size (2 levels) with the bandwidth and packet loss rate used as the metrics for QoS. The resulting full factorial DOE is defined by Table 2, where test results are shown for the Steep Hollow location using the wireless cards from Provider 2. Each experiment is repeated three times to reduce the effect of randomness, which leads to a total of 18 experiments per network provider. Since we have access to two network providers, we ran a total of 36 experiments.

Note from Table 2 that small packet sizes were chosen in the experiments. For instance, for voice communications, the packet sizes can range from less than 100 bytes for G.723.1 codecs, to close to 500 bytes for G.711 codecs. A small buffer size (1 packet) and a large one (10 packets) are used. Data streaming rates of 500 kbps are used for all the experiments.

TABLE 2. FULL-FACTORIAL DOE EXPERIMENTS (PROVIDER2)

Test No.	Packet Size (bytes)	Buffer Size (packets)	Mean Bandwidth (kbps)	Mean packet loss rate (%)
1	100	1	88.57	16.48
2	100	10	106.16	0.11
3	500	1	132.15	0.24
4	500	10	131.39	0.14
5	1000	1	125.75	0.13
6	1000	10	136.54	0.10

Test quality

To help understand the statistical nature of our analysis, a typical statistical distribution of the bandwidth from an experiment is displayed in Fig. 5.

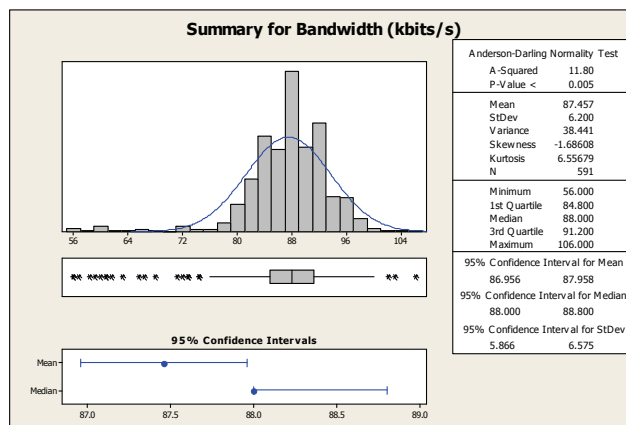

Figure 5. Statistical distribution of bandwidth.

The p-value is less than 0.005, thus it is not a normal distribution. For every test conducted, average values and standard deviations are calculated. The ratio between the average and the standard deviation is defined as the signal to noise ratio (SNR).

TABLE 3. SNR FOR BANDWIDTH, WHERE L1 IS LOCATION 1 (FERMIER BASEMENT), L2 IS LOCATION 2 (STEEP HOLLOW), C1 IS PROVIDER 1, C2 IS PROVIDER 2.

Test No.	L1/C1	L1/C2	L2/C2	L2/C1
1	4.00	1.96	16.67	14.29
2	3.33	2.22	25.00	14.29
3	2.50	2.5	20.00	12.50
4	1.92	2.33	20.00	12.50
5	2.33	2.00	14.29	12.50
6	3.13	1.87	25.00	12.50

Thus, the SNR is clear indication of quality of the tests. From Table 3, it is clear that L2, i.e., Steep Hollow, is the more reliable location due to its higher SNR. The definition of the SNR may not appropriate for signals that have mean values close to zero. For this reason, the SNR for packet loss rate is not used.

V. ANALYSIS OF RESULTS

In this section, the results of the DOE for each location and each wireless card are carefully analyzed using the Main Effects and the Interaction Plots for bandwidth and packet loss rate. Such plots are obtained from Minitab [3] software tool. Then, we combine the different locations and wireless cards in one common four-factor DOE, and the interaction between the variables are analyzed using Pareto Charts of the Effects. Finally, to further analyze the effect of packet size on the packet loss rate and bandwidth, we show the results of experiments using a combination of seven different packet sizes, from 100-byte to 1400-byte packets.

A. Provider 2, Steep Hollow – Bandwidth and Packet Loss Rate

The Main Effects Plots for bandwidth and packet loss rate are shown in Fig. 6. Levels 1, 2, and 3 for packet size represent 100, 500, and 1000 bytes respectively. Levels 1 and 2 for buffer size represent 1 and 10 packets.

The Main Effects Plot for bandwidth shows that the impact of the packet size on the bandwidth is highly nonlinear. There is a significant increase in the bandwidth when the packet size changes from 100 to 500 bytes. The change corresponding to the increase of the packet size from 500 to 1000 is very small. The effect of the buffer size is not as significant compared to packet size change from 100 to 500, but is significant compared to the change of packet size from 500 to 1000. High bandwidth is achieved when the packet size is 500 or 1000 bytes. High bandwidth is achieved when the buffer size is 10 packets.

The Main Effects Plot for packet loss rate shows that the impact of the packet size on the packet loss rate is also highly nonlinear. There is a significant decrease in the packet loss rate when the packet size changes from 100 to 500 bytes. To support this, let us take a look at the particular case of 100-byte packets. Note that in Table 2 the mean packet loss rate for Test No.1 was much higher (16.48%) than the other tests, which all had less than 0.5% of mean packet loss rate. This difference is indeed significant and we need to verify if this is always true when we have 100-byte packets and a very small buffer. To verify this, we need to analyze the results in other locations, and with other wireless cards. The results in Table 2 reflect only the performance in Steep Hollow and wireless card 2, which as discussed in Section III, has poor coverage by Provider 2.

Notice that at the 500 to 1000-byte range, the change in packet loss rate corresponding to the increase in packet size is very small. The effect of the buffer size on the packet loss rate is significant. Based on the DOE analysis, low packet loss rate is achieved when the packet size is 500 or 1000 bytes. Low packet loss rate is achieved when the buffer size is 10 packets. Based on these two graphs, one can conclude that for optimal QoS in this location and for this wireless provider, the packet size should be greater than or equal to 500 bytes and the buffer size should be large, i.e., 10-packet size. Of course, these conclusions are limited to the ranges between the levels specified in Table 1. Also, if the value for the buffer size is too large, there may be an issue with delays [17].

B. Provider 1, Steep Hollow – Bandwidth and Packet Loss Rate

Similar graphs are plotted in Fig. 7 for the same DOE test conducted at the same location (Steep Hollow) using Provider 1’s wireless card. It can be seen that the general trends for the two wireless cards are similar. One must be very careful not to draw a conclusion that this is always true since the results may be dependent on the location.

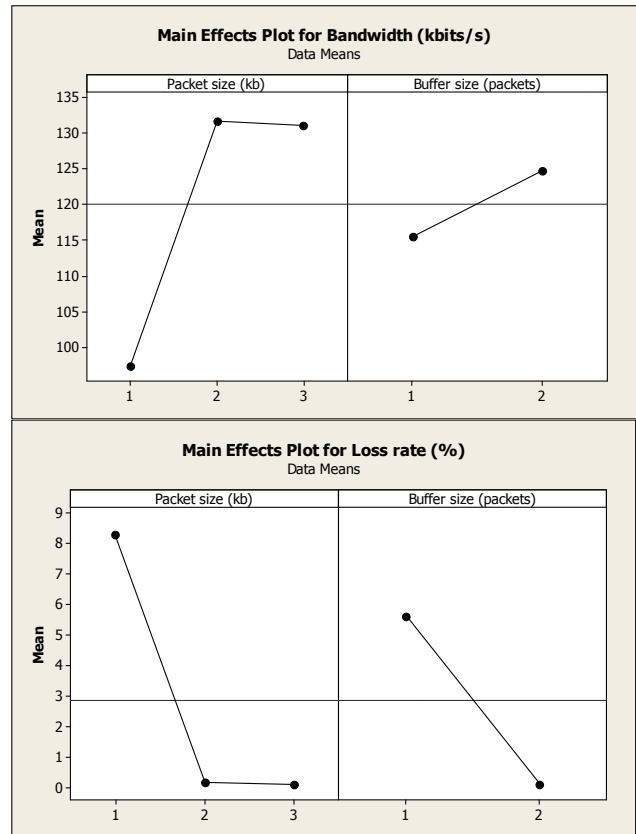

Figure 6. Main Effects Plots (Provider 2, Steep Hollow).

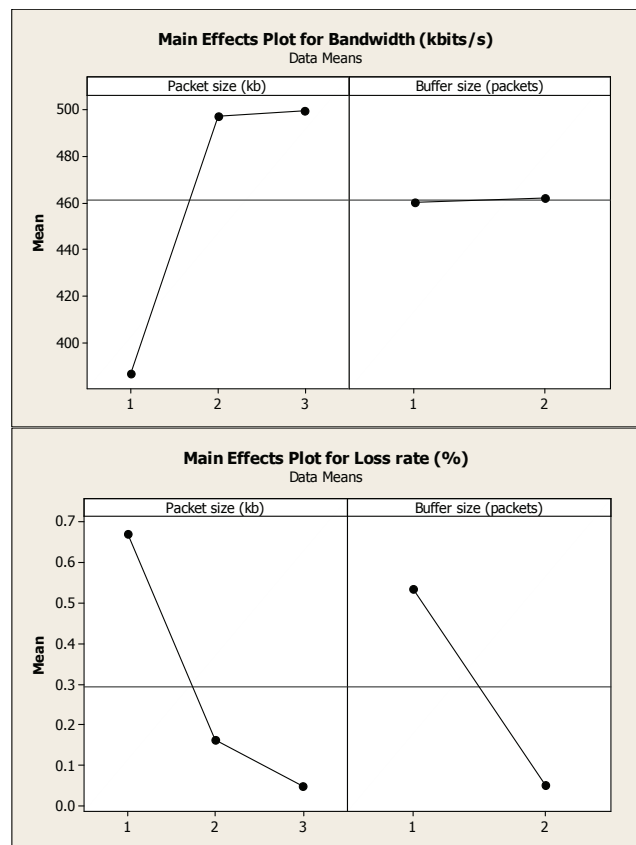

Figure 7. Main Effects Plots (Provider 1, Steep Hollow).

C. Provider 2, Fermier basement – Bandwidth and Packet Loss Rate

The dependency on location is illustrated in Fig. 8 by the result from the same DOE test conducted at a different location (Basement of Fermier Hall on the Texas A&M University campus). In this case, one can see a significant difference between the bandwidth Main Effects Plots in Fig. 8 and the results obtained in the other location (Fig. 7). On the other hand, the packet loss rate, also shown in Fig. 8, still has similar characteristic as those in Fig. 7.

D. Four-factor full factorial DOE

The test data from the DOE defined in Table 2 collected at the two different locations and with two different wireless cards can be used to conduct a four-factor full factorial DOE analysis for packet size, buffer size, location, and wireless card. The DOE matrix and the test results are given in Table 4.

There are different graphs that can be used to illustrate the DOE analysis results. The Pareto Charts of the Effects for bandwidth and packet loss rate are shown in Fig. 9. With a confidence level of 95%, which is $1 - \text{Alpha}$, one can conclude that the main factors for bandwidth are the wireless card and location, as indicated by the corresponding values for these factor over the threshold of 2.571.

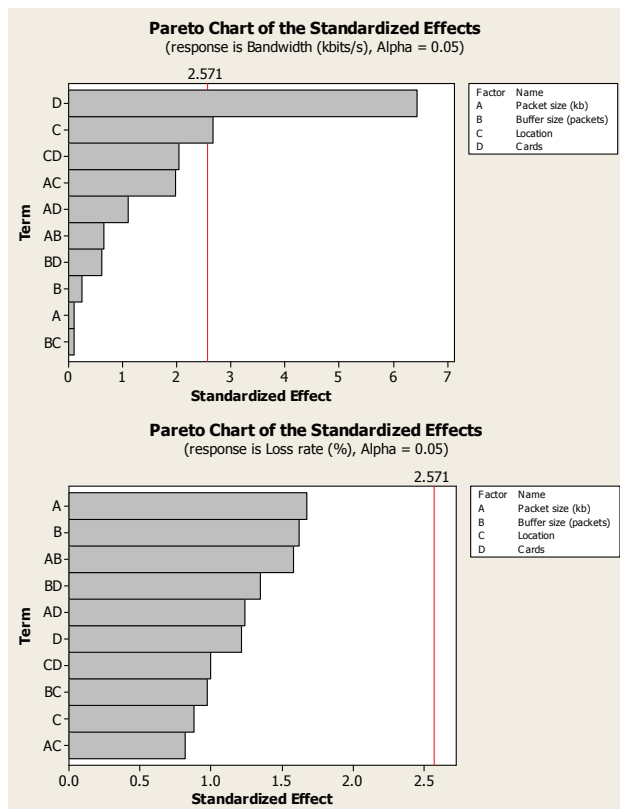

Figure 9. Pareto charts for four-factor DOE.

However, it was not possible to determine the most significant factor for the packet loss rate. For every second, the packet loss rate is calculated, giving us 600 samples in 10 minutes testing. The packet loss rates are typically very low, less than 1%, due to all the error encoding and correction capabilities implemented in 3G systems. Occasional bursts of packet losses have been observed in the experiments. Because our metric is the mean packet loss rate, these bursts have been averaged leading to the results in the last column in Table 4 as well as the conclusions from the Pareto Chart for packet loss rate. Although most of the mean packet loss rate values are low, we can observe in Table 4 that higher packet loss rates were obtained for the rural location (Steep Hollow) with wireless card 2 (Tests 9 to 12).

E. Further testing

As discussed earlier, the impact of the packet size on the bandwidth is highly nonlinear. The previous DOE tests only had three different values for packet size. In order to characterize the nonlinearity in the impact of the packet size on QoS, further tests were conducted at the Steep Hollow location using the two wireless cards. Since buffer size was determined to have insignificant impact on the bandwidth results (Fig. 9), the buffer was chosen to be of size 10 packet. The packet sizes were selected to be 100, 200, 300, 400, 500, 1000, and 1400 bytes. The selection of the packet sizes were based on the results from the DOE analysis, which indicate that there was a significant change between 100 and 500 bytes but not much change between 500 and 1000 bytes. The results for bandwidth are summarized in Fig. 10 and Fig. 11, with an input data streaming rate of 500 kbps.

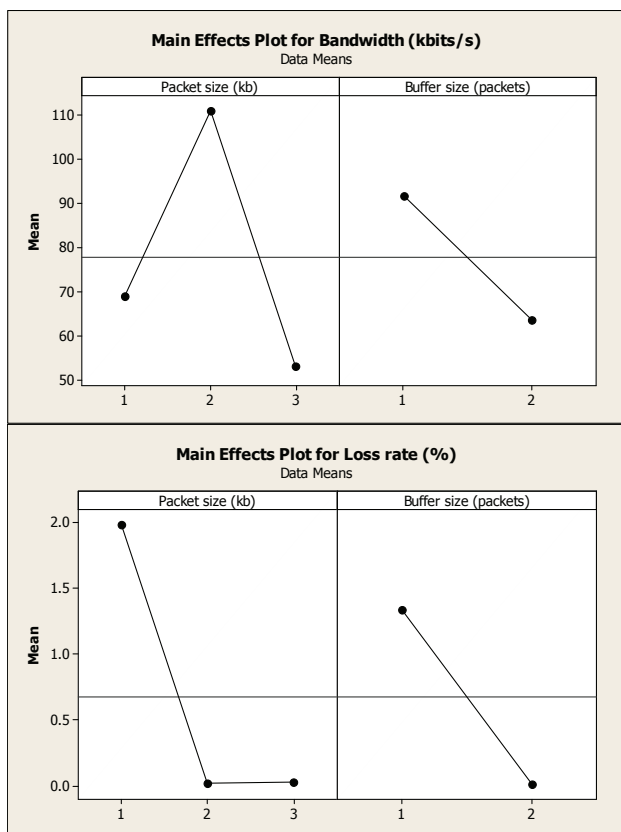

Figure 8. Main Effects Plots (Provider 2, Fermier basement).

TABLE 4. FOUR-FACTOR FULL FACTORIAL DOE

Test No.	Packet Size (bytes)	Buffer Size (packets)	Location	Wireless card	Mean Bandwidth (kbps)	Mean packet loss rate (%)
1	100	1	Steep Hollow	Card1	385.03	1.28
2	500	1	Steep Hollow	Card1	496.35	0.29
3	100	10	Steep Hollow	Card1	389.44	0.06
4	500	10	Steep Hollow	Card1	497.22	0.04
5	100	1	Fermier Basement	Card1	305.82	1.43
6	500	1	Fermier Basement	Card1	150.50	0.05
7	100	10	Fermier Basement	Card1	416.04	0.84
8	500	10	Fermier Basement	Card1	165.92	0.20
9	100	1	Steep Hollow	Card2	88.57	16.48
10	500	1	Steep Hollow	Card2	132.15	0.24
11	100	10	Steep Hollow	Card2	106.15	0.11
12	500	10	Steep Hollow	Card2	131.39	0.14
13	100	1	Fermier Basement	Card2	65.84	3.95
14	500	1	Fermier Basement	Card2	150.50	0.05
15	100	10	Fermier Basement	Card2	72.44	0
16	500	10	Fermier Basement	Card2	71.21	0

It can be easily seen that the most important factor is the coverage. At the test location, the wireless card 1 has good coverage and wireless card 2 has poor coverage. The bandwidth for card 1 is almost four times higher than that of card 2. The performance of card 1 is also more consistent. It can be concluded that using card 1 at the test location, the packet size should be chosen as 200 bytes or larger. If card 2 is used, then the performance is not consistent. There was too much noise in the measurements. In general, packet sizes above 500 bytes have better results.

When analyzing mean packet loss rate (Fig. 11), card 1 has lower packet loss rate due to good coverage and the larger packet size has lower packet loss rate in general, except for packet size 100 byte. Since both bandwidth and packet loss rate are important metric for performance, packet sizes greater than or equal to 500 bytes provide better overall result. Similar to the bandwidth plot, the packet loss rate for card 2 is inconsistent. However, we can observe that larger packet sizes have lower packet loss rate and are typically more efficiently transmitted.

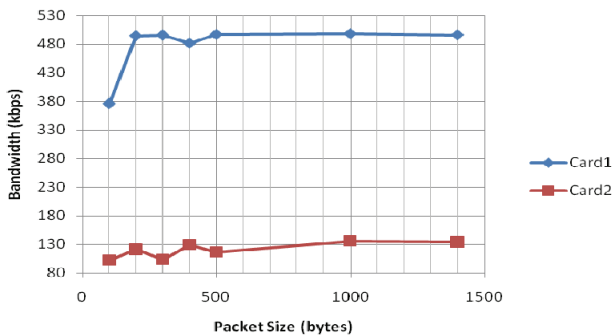

Figure 10. Bandwidth as a function of packet size (Steep Hollow).

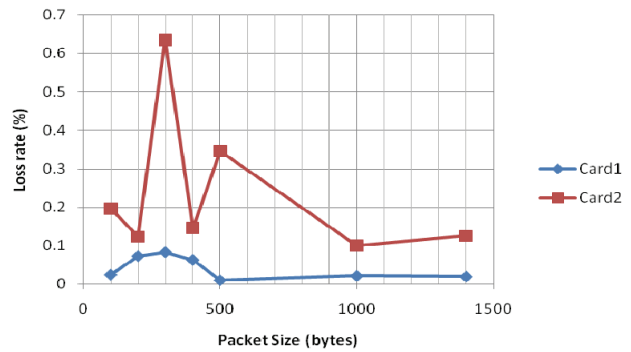

Figure 11. Packet loss rate as a function of packet size (Steep Hollow).

VI. CONCLUSIONS

This paper presents an innovative way to study the simultaneous effects of multiple variables on the throughput and packet loss rate using the Design of Experiment (DOE) method. Real world test data are used in this paper. Statistical analysis is conducted with the test data that has noise and multiple factors influencing the test results. Note that the statistical analysis method here presented is certainly not limited to the applications of 3G wireless communication systems. Any wireless communication system that has specific QoS requirements can potentially benefit from similar analysis.

In our initial DOE experiment, a two-factor multi-level DOE matrix was presented. It allowed us to study the impact of packet size (3 levels) and buffer size (2 levels) on the bandwidth and packet loss rate. The tests were conducted at different locations (a rural and an urban location) and with different wireless cards. The results show that the impacts of the two factors on the effective bandwidth and mean packet loss rate are

dependent on the location and the wireless card used, whereas the impact of buffer size is less significant. Based on the DOE analysis, additional tests were conducted in the rural location to study the nonlinearity in the bandwidth and packet loss rate as functions of the packet size. For the location of Steep Hollow, if Provider 1 or Provider 2 wireless card is used, better QoS can be achieved when the packet size is 500 bytes or greater. Additionally, we concluded that very small packet sizes such as 100-byte packets and very small buffers should be definitely avoided in places of poor coverage. The difference in bandwidth from Provider 1 (good coverage) and Provider 2 (poor coverage) was almost 400%, for the same uplink data streaming rate.

The results in this paper help one to better understand the impact of wireless card, location, packet size, and buffer size, for uplink real-time transmission in 3G wireless communication systems. The findings from this study can be used to calibrate application parameters for stationary users that depend upon 3G systems for high-speed Internet access. Adjusting parameters such as packet size, buffer size, location of receiving antenna, and, if possible, choice of wireless provider can significantly improve QoS. We showed that the selection of optimal system parameters is highly dependent on the location of the mobile unit and the wireless card used.

Furthermore, the test data shows that one must be careful in using actual experimental data collected from areas that do not have good coverage, such as rural areas. To achieve better result for wireless communication in rural areas, it is best for a mobile unit to be equipped with multiple wireless cards since the QoS can vary significantly for different locations. Our ultimate goal is to develop an easy-to-use software package that can automatically perform the DOE analysis within a short period of time such that the user can select the best communication parameters for their mobile applications.

Additional DOE experiments will also be conducted to analyze the effect of buffer size on jitter, and also to identify the impact of occasional packet loss bursts in the QoS of real-time applications.

REFERENCES

- [1] A. Dulski, H. Beijner, and H. Herbertsson, "Rural W-CDMA – Aiming for nationwide coverage with one network, one technology, and one service offering." *Ericsson Review – The telecommunications journal*, vol. 2, 2006.
- [2] P. Bender, P. Block, M. Grob, R. Padovani, N. Sindhushayana, and A. Viterbi, "CDMA/HDR: A bandwidth-efficient high speed wireless data service for nomadic users." *IEEE Communications Magazine*, vol. 8(7), pp. 70-77, 2000.
- [3] R. Meyer, and D. Krueger, *A Minitab guide to statistics*, 3rd Edition, Prentice Hall, 2005.
- [4] A. Goulart, and W. Zhan, "A Design of Experiment (DOE) Analysis of the Performance of Uplink Real-Time Traffic over a 3G Network," in the Proceedings of the 4th IEEE International Conference on Wireless & Mobile Computing, Networking & Communication (WiMob), October 2008.
- [5] A. Alexiou, C. Bouras, and V. Igglesis, "Scalable rate control for video transmission over UMTS." *International Journal of Communication Systems*, vol. 20(12), pp. 1315-1335, 2007.
- [6] A. Basso, B-J. Kim, Z. Jiang, "Performance evaluation of MPEG-4 video over realistic EDGE wireless networks." In the Proceedings of the 5th International Symposium on Wireless Personal Multimedia Communications, vol. 3, pp.1118-1122, October 2002.
- [7] A. Schieder, U. Horn, and R. Kalden, "Performance analysis of realtime applications in mobile packet switched networks." *ITG-Fachbericht, European Wireless'99*, 1999.
- [8] Y. Lee, "Measured TCP performance in CDMA 1x EV-DO Network," In the Proceedings of the Passive and Active Measurement Conference, 2006.
- [9] A. Jalali, R. Padovani, and R. Pankaj, "Data throughput of CDMA/HDR a high efficiency-high data rate personal communication wireless system." In the Proceedings of the IEEE 51st Vehicular Technology Conference, vol. 3, pp. 1854-1858, 2000.
- [10] Qi Bi, S. Vitebsky, "Performance Analysis of 3G-1X EVDO High Data Rate System," In the Proceedings of the Wireless Communications and Networking Conference (WCNC), 2002.
- [11] Y. Chu, and A. Ganz, "A Mobile Teletrauma System Using 3G Networks", *IEEE Transactions on Information Technology in Biomedicine*, vol. 8 (4), pp. 456-462, 2004.
- [12] J. Cullen et al., "Wireless mobile telemedicine: En-route transmission with dynamic quality-of-service management", *National Library of Medicine Symposium on Telemedicine and Telecommunications: Options for the New Century*, 2001.
- [13] R.S.H. Istepanian, B. Woodward, and C.I. Richards, "Advances in telemedicine using mobile communications", In the Proceedings of IEEE Engineering Medicine and Biology Society, vol. 4, pp. 3556–3558, 2001.
- [14] D. Komnakos, D. Vouyioukas, I. Maglogiannis, and P. Constantinoul, "Performance Evaluation of an Enhanced Uplink 3.5G System for Mobile Healthcare Applications," *International Journal of Telemedicine and Applications*, Article ID 417870, 2008.
- [15] B. Konstantinos, "Use of 3G mobile phone links for teleconsultation between a moving ambulance and a base station." *Journal of Telemedicine and Telecare*, vol. 12(1): pp. 23-26, 2006.
- [16] S. Pavlopoulos et al., "A novel emergency telemedicine system based on wireless communication technology – AMBULANCE", *IEEE Transactions on Information Technology in Biomedicine*, vol. 2, pp. 261-267, 1998.
- [17] E. A. Viruete Navarro, J. Ruiz Mas, J. Fernández Navajas, C. Peña Alcega, "Performance of a 3G-Based Mobile Telemedicine System," In the Proceedings of the IEEE CCNC , pp. 1023-1027, 2006.
- [18] Y. Xiao, D. Gagliano, M. LaMonte, P. Hu, W. Gaasch, R. Gunawadane, and C. Mackenzie, "Design and evaluation of a real-time mobile telemedicine system for ambulance transport," *High Speed Networks*, vol. 9 (1), pp. 47-56, 2000.
- [19] R. E. Ewing, L. Flournoy, and J. Wall, *Texas A&M University Disaster Relief and Emergency Medical Services (DREAMS)*. Technical Report, November 2006.
- [20] G. Sahai, A. Goulart, W. Zhan, and R. Arnold , "Optimal Selection of Wireless Channels for Real-Time Communication in Ambulances," In the Proceedings of the IEEE Radio and Wireless Symposium, January 2008.
- [21] Georgetown University Hospital/MedStar Health KIDS Mobile Medical Clinic, A Verizon White Paper:

http://b2b.vzw.com/assets/files/VWS60176_Grgtwn_Meds tar_CS_v1d.pdf

- [22] G. Parr, "Military communications and technology", *Computer Networks*, vol. 46 (5), pp. 575-579, 2004.
- [23] Iperf, <http://dast.nlanr.net/projects/lperf>.
- [24] P. Rodriguez, et al., "MAR: A Commuter Router Infrastructure for the Mobile Internet," In the Proceedings of ACM MobiSys, 2004.

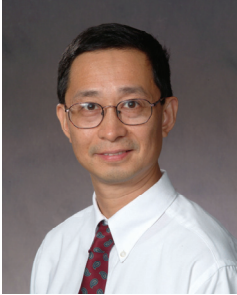

Wei Zhan was born in Zhejiang province, China, in 1963. He received his bachelor's degree in electrical engineering from Beijing University of Aeronautics and Astronautics in 1983. He received his M.S. and D.Sc. degrees in systems engineering and systems science, respectively, from Washington University, in St. Louis, MO, USA, in 1988 and 1991.

He is currently an Assistant Professor in the Electronics and Telecommunications Engineering Technology program at Texas A&M University, in College Station, TX. Before joining Texas A&M, he also worked at TRW Automotive, Wayne State University, and University of California, San Diego.

Dr. Zhan is a senior member of IEEE, a member of Society of Automotive Engineers (SAE), a member of American Society of Engineering Education (ASEE), and a member of American Society for Quality (ASQ).



Ana E. Goulart was born in the province of Minas Gerais, Brazil, in 1970. She received a bachelor's degree in electrical engineering from the Federal School of Engineering of Itajuba (EFEI) in 1992. While working in the industry, she received a M. Sc. degree in Information Systems Management from the

Pontifical Catholic University of Campinas, in 1997. She moved to the United States in 1997 where she earned a M. Sc., in Computer Engineering at North Carolina State University, Raleigh, NC; followed by a Ph.D. in Electrical and Computer Engineering at Georgia Tech, Atlanta, GA, in 2005.

She is currently an Assistant Professor in the Electronics and Telecommunications Engineering Technology program at Texas A&M University, in College Station, TX. Her research interests include wireless communications, protocols for real-time voice and video communications, networked robotics, and rural telecommunications.

Dr. Goulart is a member of the IEEE Communications Society, IEEE Education Society, American Society of Engineering Education (ASEE), and the International Telecommunications Education Research Association (ITERA).