

# Automatic Detection of the Guard Interval Length in OFDM System

Li Zou

Thomson Broadband R&D (Beijing) Co. Ltd

Li.Zou@thomson.net

**Abstract**— Orthogonal Frequency Division Multiplexing (OFDM) has been increasingly used in wireless broadband communication systems. Guard interval (GI) is used in OFDM system to reduce inter-symbol interference (ISI). As selection of the length of guard interval depends on the channel condition, the length of guard interval will change dynamically. Thus there must be a way to synchronize this parameter between the transmitter and the receivers. Traditional OFDM systems require a transmitter to notify its receivers using additional signal and thus result additional bandwidth. In addition, this complicates the initiation process for an OFDM receiver as it has to search through all the possible values of GI length to find the parameter used by the transmitter. To address this problem, this paper gives a low-complexity method, which can detect the length of guard interval at the receiver without any guard interval length information from the transmitter. The introduction of this method will reduce the additional signaling and simplifies OFDM systems. Both theoretical analysis and simulation results show that the proposed method has good performance. The proposed method can give accurate measure of GI length under both AWGN and Rayleigh Channel even when SNR is as low as 3dB.

**Index Terms**—OFDM, Guard Interval

## I. INTRODUCTION

Orthogonal Frequency Division Multiplexing (OFDM) enables robust multiple-access technology to combat the impairment of wireless channels, especially of multi-path fading, delay spread, and Doppler shifts. Because of its significant advantages in frequency efficiency, OFDM is widely used in broadband communication area. In 1995, European Digital Audio Broadcasting (DAB) standard is the first broadcasting standard using OFDM [11]. In Europe, OFDM has been employed in the digital terrestrial video broadcasting (DVB-T) [6] and Terrestrial Integrated Service Digital Broadcasting (ISDB-T specification). It can also be used in local area networks such as HyperLAN/2, IEEE 802.11 a/g/n [12] and WiMax [13]. It is a competitive modulation technique used in the mobile communication systems [1]. Most recently, modern Ultra-Wideband (UWB) [14] systems use OFDM modulation in combination with multiple bands to provide significant advantages over traditional UWB systems [15].

In an OFDM system, the length of the guard interval needs to be changed according to the environment to

make efficient use of the communication channels. Usually, a transmitter chooses the GI length, and informs the receiver. This, however, results in reduced bandwidth efficiency. Furthermore, in initiation stage, a receiver follow this protocol is required to search through all possible modes to determine the correct guard interval length. Such scheme will result a long initiation process. Especially when COFDM is employed in digital broadcasting handheld terminals such as DVB-H and DMB-T systems, long detection process will result long channel switching time. All these problems can be eliminated if the receiver can automatically detect the length used by the transmitter. Another feature for this adaptive detection method is to make it system-independent. Shiou-Hong Chen proposed a mode detection algorithm to make the DVB-T receiver system-independent. But it can only detect 2K or 8K mode, but can not distinguish the guard interval length [8].

In this paper, we propose a time domain algorithm, which exploits the relationship between signal autocorrelation and symbol energy in OFDM systems. With this algorithm, the receiver will be able to automatically initiate the communication and track the changes.

This paper is organized as follows. In Section 2, we give a brief introduction of OFDM systems. Then, we present the new algorithm in section 3. An improvement to the basic algorithm is presented in section 4, followed by the simulation results in Section 4. In the Section 5, we summarize the paper.

## II. OFDM SYSTEM

In this section, we will give a very brief review of OFDM system and address the problem we are to solve.

Orthogonal Frequency Division Multiplexing was first proposed by R.W. Chang in 1966 [10]. In an OFDM system, the transmitter performs inverse Fast Fourier Transformation (IFFT) and modulates the resulted data using a standard modulation scheme such as PSK, QAM, etc (Figure 1). The modulated signals are then sent through the wireless channel. The receiver demodulates the received signals and performs FFT to reconstruction the original data.

By using FFT techniques, a broadband signal is separated into a set of low rate signal transmitted over a set of low data rate sub-band with each sub-band

corresponding to a sub-carrier. Since each sub-band has limited bandwidth, this simplifies equalization since channel response is roughly flat in a sub-band. In addition, an OFDM system allows very accurate control of output signal frequency spectrum. This leads to high

bandwidth efficiency. Zou and Wu gave a more detail introduction of OFDM systems [9].

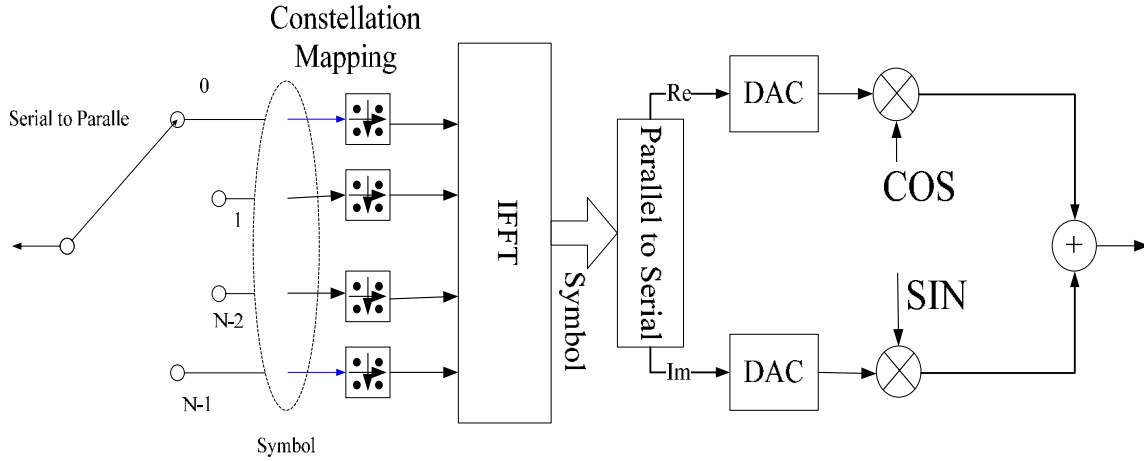

Figure 1 OFDM modulation

To facilitate IFFT/FFT, each symbol in an OFDM system contains N (IFFT/FFT size) samples. Guard interval (GI) of L samples is inserted before each sample to protect the system against inter-symbol interference (ISI). A guard interval of length L contains the last L samples of the symbol following it (Figure 2).

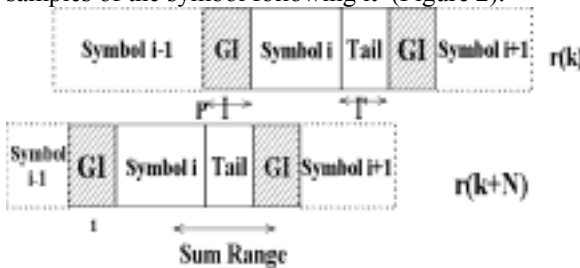

Figure 2 the structure of OFDM symbol

III. BASIC ALGORITHM

A. Algorithm Procedure

Our algorithm is to determine the GI length L directly from the received signal and thus avoids the cost associated with additional signaling. This algorithm uses the autocorrelation of  $r(k)$  (the received samples) to determine the GI length selected by the transmitter from a GI length option set  $LS = \{L_1, L_2, \dots, L_q\}$ .

The basic algorithm works as described below.

First, the sum of autocorrelations of the received signals is calculated as follows.

$$F(\theta) = \sum_{k=\theta}^{\theta+M-1} \{r(k)r^*(k+N)\} \quad [1]$$

Here N is the size of a FFT block. M determines the range of the summation. M should be so selected that there is one and only one GI between  $r(\theta)$

and  $r(\theta + M - 1)$ .  $\theta$  is the location of the first sample in the summation range. The selection of  $\theta$  does not change result.

In the second step, the average energy in the received signal segment is calculated.

$$R(\theta) = \frac{1}{M} \sum_{k=\theta+1}^{\theta+M} r(k)r^*(k) \quad [2]$$

In the third step, the estimation of the GI length can be given as follows, where  $\rho = \frac{SNR + 1}{SNR}$  and SNR denotes signal-to-noise ratio.

$$\hat{L} = \rho \frac{F}{R} \quad [3]$$

Finally, the estimated GI length  $\hat{L}$  can determine the GI length selected by the transmitter.

B. Analysis of the Algorithm

Let  $r(p), \dots, r(p+L-1)$  be the GI in the sum sequence. Here p is the starting position of the GI and L is the length of GI. Both of them are unknown variables.

Under additive white Gaussian noise (AWGN) channel, the correlation of the samples is shown as follows [2].

$$\forall k \in I, \quad E\{r(k)r^*(k+t)\} = \begin{cases} \sigma_s^2 + \sigma_n^2 & t = 0 \\ \sigma_s^2 e^{-j2\pi\epsilon t} & t = N \\ 0 & otherwise \end{cases} \quad [4]$$

Here  $\sigma_s^2$  is the average energy of a received sample,  $\sigma_n^2$  is the average additive noise energy and  $\varepsilon$  denotes the frequency difference between the transmitter and receiver oscillators normalized by the inter-subcarrier spacing. The concept of this formula is that if  $r(k+t)$  is a copy of  $r(k)$ , then the correlation expectation is the sample energy rotated by the degree  $\varepsilon$ . If  $r(k)$  and  $r(k+t)$  are two uncorrelated sample, the correlation expectation is zero. If  $t=0$ , the expectation is the energy of both signal and noise.

According to the formula [4], when  $r(k)$  is in a guard interval, the term  $r(k)r^*(k+N)$  has an expectation of  $\sigma_s^2 e^{-j2\varepsilon\pi}$ . All the other values of the term  $r(k)r^*(k+N)$  have a zero expectation. The summation range in (1) contains only one guard interval. If  $L$  is the length of an guard interval, then

$$E(F) = L\sigma_s^2 e^{-j2\varepsilon\pi} \quad [5]$$

Based on [2] and [4], we also have

$$\begin{aligned} E[R(\theta)] \\ = \frac{1}{M} \sum_{k=1}^M E[r(k)r^*(k)] = \sigma_s^2 + \sigma_n^2 \end{aligned} \quad [6]$$

Since  $M \gg 1$ ,  $R$  is a good approximation of  $E(r(k)r^*(k)) = E(R)$ . Thus  $|R - E(R)| \ll E(R)$ . Finally by putting formula [3], [4], and [5] together, we have the absolute value of the mean of  $\hat{L}$ :

$$\begin{aligned} |\mu| \\ = |E(\hat{L})| \\ = \left| \frac{1}{E(R)} \cdot E \left( \frac{F}{1 + \frac{R - E(R)}{E(R)}} \right) \cdot \rho \right| \\ \approx \left| \frac{1}{E(R)} \cdot \left( E(F) - E \left( \frac{F \cdot (R - E(R))}{E(R)} \right) \right) \cdot \rho \right| \\ \approx \left| \frac{E(F)}{E(R)} \cdot \rho \right| = L \end{aligned} \quad [7]$$

Similarly, the standard variance of  $\hat{L}$  can be calculated as follows.

$$\begin{aligned} \sigma &= \sqrt{E(\hat{L}^2) - \mu^2} \\ &\approx \sqrt{M - L + \frac{M}{SNR}} \end{aligned} \quad [8]$$

The formula [3] indicates that  $\hat{L}$  is an estimation of  $L$ .

In formula [7], the accuracy of  $\hat{L}$  depends on the selection of the summation range and channel condition. In the following section, we will discuss the algorithm for selecting summation range  $M$ .

### C. Improving the basic algorithm

In the above method, it is required that the summation range must covers one and only one guard interval. Without knowledge of the location of guard intervals and the length, such a condition is difficult to meet. In this improved algorithm, we will address this issue.

The basic idea of determining  $M$  is based on [4]. It is clear that  $E[r(k)r^*(k+N)]$  can, in theory, indicate whether  $r(k)$  is in a guard interval. However, in practice, it is difficult since the difference between the two types of sample correlation terms  $r(k)r^*(k+N)$  is not large enough for robust GI length detection.

Figure 2 shows an example of the magnitudes of sample correlation term  $r(k)r^*(k+N)$  changing with the position of sample  $r(k)$ . Here the OFDM signal has a 2048 sub-carriers, a 1/8 guard interval, and a signal-to-noise ratio (SNR) is 4dB, where the SNR is the total signal (all the sub-carriers) to noise power ratio. From the figure, we can see that the difference between the two type of sample correlation, i.e. correlation when  $r(k)$  is in a guard interval and correlation when  $r(k)$  is not in a guard interval, is covered by random noises. Based on the above analysis, we know that if we use the average of a set of correlation samples, the sum will be a better indicator for a guard interval as random noise will be suppressed during the average.

Let  $m$  be a positive integer less than or equal to the shortest length of GI. We define a sum of  $m$  correlation samples  $\phi(\theta)$  as following.

$$\phi(\theta) = \sum_{k=\theta}^{\theta+m-1} r(k)r^*(k+N) \quad [9]$$

Here  $\theta$  denotes the starting position of the summation. The expectation of the sum can then be calculated.

$$\begin{aligned} E\{\phi(\theta)\} &= E\left\{ \sum_{k=\theta}^{\theta+m-1} (r(k)r^*(k+N)) \right\} \\ &= \begin{cases} m\sigma_s^2 e^{-j2\varepsilon\pi} & \theta \in [p, p+L-m]; \\ (m-(p-\theta))\sigma_s^2 e^{-j2\varepsilon\pi} & \theta \in [p-m, p]; \\ (L-(\theta-p))\sigma_s^2 e^{-j2\varepsilon\pi} & \theta \in [p+L-m, p+L]; \\ 0 & \text{otherwise} \end{cases} \end{aligned} \quad [10]$$

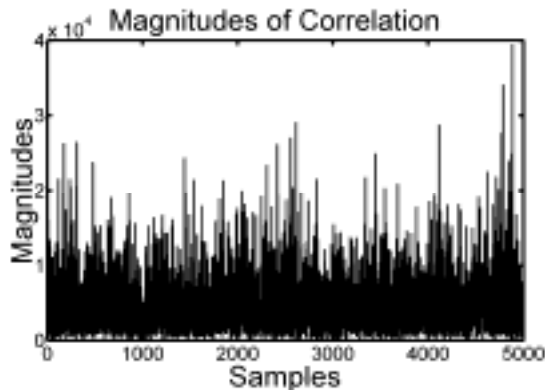

Figure 1. Example of the magnitudes of Sample correlation for Rayleigh channel

The expectation of  $\phi(\theta)$  reaches a plateau, when all of its elements are inside a GI. The expectation of  $\phi(\theta)$  is zero when none of elements falls into a GI. The distinction between these two cases can help us to ensure the summation range  $M$  covers one GI and only one GI.

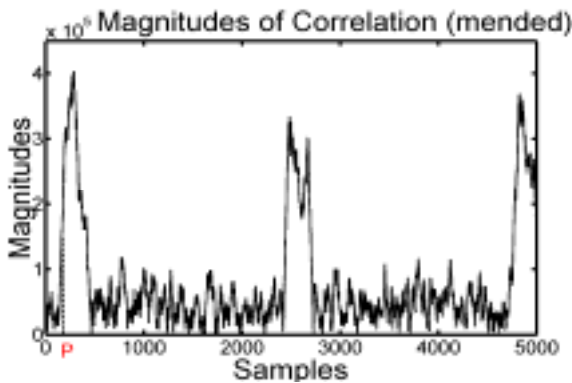

Figure 2. Example of the magnitudes of Segment correlation for Rayleigh channel

In order to compare with sample correlation, we simulate the revised algorithm under same condition as what we used for Figure 2. The magnitude of accumulated autocorrelation term  $\phi(\theta)$  is shown in Figure 3. When the elements in the segment are a subset of set I, the segment autocorrelation's magnitude reaches plateau. With an AWGN channel, the pattern is almost same except the plateau position [3]. Based on this characteristic, we can ensure that the summation range  $M$  covers just the whole plateau under any channel condition.

Accordingly, the formula [ 1 ] and [ 3 ] can be replaced as the following:

$$F(\theta) = \sum_{\omega=\theta}^{\theta+M-1} \phi(\omega) \quad [ 11 ]$$

$$\hat{L} = \rho \frac{F}{mR} \quad [ 12 ]$$

If several consecutive symbols are observed and the sums of autocorrelation are averaged, the performance of the estimator can be further improved [4].

The mean of  $\hat{L}$  is

$$E(\hat{L}) \approx \rho L \frac{\sigma_s^2}{\sigma_s^2 + \sigma_n^2} = L \quad [ 13 ]$$

As we can let  $M \approx L$ , from formula (8), we can know the standard deviation can be reduced to follows.

$$\sigma \approx \sqrt{\frac{|\hat{L}|}{SNR}} \quad [ 14 ]$$

In addition, although the algorithm is derived from a model using AWGN channel, all the signal energy is included in the signal component term unless the length of the channel impulse response is longer than the guard interval. In such a case, the energy associated with long delay becomes interference and contributes to the noise terms [5]. Therefore, this detector can be applied to frequency selective fading channels.

#### IV. SIMULATION RESULTS

The purpose of the simulations is to obtain the performance of the proposed algorithm. In simulation, we use the system parameters from European draft specification for terrestrial digital TV [6]. The OFDM system tested employs 2048 sub-carriers in an 8M bandwidth. The Rayleigh channel is used. QPSK modulation is used and  $m$  is set to 64, for its length should be no more than  $N/32$ .  $M$  equals to 320 samples.

Figure 4 shows the results of simulations performed on the Rayleigh channel when length of GI equals to 256 ( $N/8$ ). The closeness of the experimental results and theoretical prediction indicates the correctness of our above analysis and the correctness of the algorithm.

Notice that the mean of the estimated GI length is close to the actual value. The estimated value is 256 or so and it is distinct from the adjacent choices,  $N/16$  (128) or  $N/4$  (512). So the receiver can make the right decision by choosing the possible length of GI with the minimum distance. The low standard deviation shown in the Figure 4 also indicates the algorithm works robustly under Rayleigh channel. This guarantees the correct decision on the length of GI by the detector.

We simulated all possible cases under frequency selective fading channels. The detector works almost ideal for SNR values above 3dB. The judgments are almost zero error.

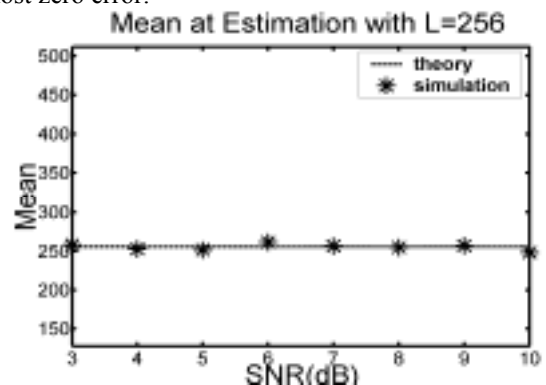

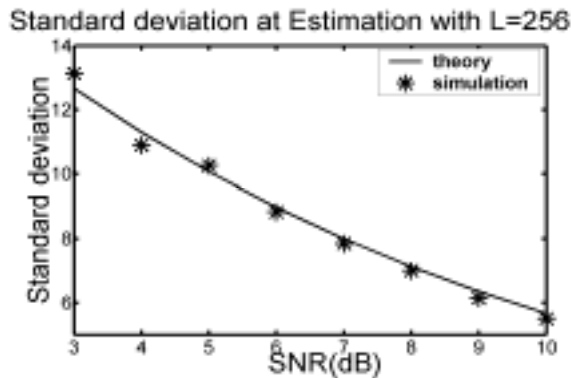

Figure 3. Mean and standard deviation at the estimation with  $L=256(N/8)$  for the Rayleigh channel

## V. CONCLUSIONS

A robust and low-complexity method for detecting the length of GI at the OFDM receiver is proposed in this paper. This method can significantly simplify the initiation process of an OFDM. The proposed method is evaluated under both AWGN channels and frequency selective fading channels.

## REFERENCES

- [1] Der-Zhang, Liu Che-Ho, Wei and Chung-Ju, Chang., "An extension of Guard-Interval Based Symbol and Frequency Synchronization Technique for Wireless OFDM Transmission" VTC 2001 fall. IEEE VTS 54th, Volume: 4, 2001
- [2] Van de Beek, Jan-Jaap, "ML estimation of time and frequency offset in OFDM systems" IEEE Transactions on Signal Processing v 45 n 7 Jul 1997
- [3] Li Zou, Yuping Zhao, Bing Wang, Qinglin Liang, "A Joint Total Number of Subcarriers and Guard Interval Length Detector in OFDM Systems". IEEE proceeding of the ICT2002, Volume 1, 2002
- [4] Van de Beek, "Three non-pilot based time- and frequency estimators for OFDM" Signal Processing 80 7 Jul 2000 Elsevier Science Publishers
- [5] Timothy M. Schmidl and Donald C.Cox "Robust Frequency and Timing Synchronization for OFDM" IEEE Transactions on Communications V 45 No 12 Dec 1997
- [6] "ETS 300 744, "Digital Broadcasting Systems for Television, sound and data services; Framing Structure, Channel Coding and Modulation for Digital Terrestrial Television," ETSI EN 300 744 V1.2.1, 1999
- [7] Wu, yiyang, "Performance Comparison of ATSC 8-VSB and DVB-T COFDM Transmission System for Digital Television Terrestrial Broadcasting" IEEE Transaction Consumer Electronics v45 No.3, 1999 p916-924
- [8] Shiou-Hong Chen, Way-Hong He, Hou-Shine Chen, Yumin Lee, "Mode Detection, Synchronization, and channel estimation for DVB-T OFDM receiver," Global Telecommunications Conference, 2003, GLOBECOM'03, IEEE.
- [9] Zou, W.Y., Yiyang Wu, "COFDM: an overview", IEEE transaction on Broadcasting, v 41 n 1 Mar 1995.
- [10] R.W. Chang. Synthesis of band-limited orthogonal signals for multi-channel data transmission, Bell System Technical Journal 46, 1775-1796, 1966
- [11] DAB Standard pr ETS 300 401, "Radio Broadcasting system; Digital Audio Broadcasting (DAB) to mobile, portable and fixed receivers", 1995
- [12] ASTM E2213-03, "Standard Specification for Telecommunications and Information Exchange Between Roadside and Vehicle Systems 5 GHz Band Dedicated Short Range Communications (DSRC) Medium Access Control (MAC) and Physical Layer (PHY) Specifications"
- [13] IEEE Std 802.16e-2005, "IEEE Standard for Local and metropolitan area networks Part 16: Air Interface for Fixed and Mobile Broadband Wireless Access Systems Amendment for Physical and Medium Access Control Layers for Combined Fixed and Mobile Operation in Licensed Bands"
- [14] Ghorashi, S.A, Allen. B, Ghavami,M; Aghvami,A.H,"An overview of MB-UWB OFDM," 16~19 Nov.2003, Digital Object Identifier 10.1109/UWBST.2003.1267863
- [15] Liuqing Yang; Giannakis.G.B, "Ultra-wideband communications: an idea whose time has come," Volume 21, Issue 6, Nov. 2004

**Li Zou** received a Ph.D degree from department of Electronics in Peking University in 2003. She also held a B.S. degree from department of Electrical Engineering in Nanjing University..

She is the group leader of communication team in Thomson corporate research Beijing site, in China. She is responsible for Digital Video Broadcasting demodulator design and FPGA-based prototyping. Before joining in Thomson, she made in-depth research on OFDM system, MIMO system, channel coding & modulation systems and network protocols. As a key member, she contributed to a large-scale network platform planning, design and development in EE department of Peking University.

Dr. Zou is IEEE member. She published more than 10 papers on international Journals and conferences such as Science in China, Journal of Electronics & Information Technology, etc.